



ASSEMBLY INSTRUCTIONS

Melbourne

ITEM NO.:

- K4725XLE Teak Electric Lift
- K4725XLH Teak Hydraulic Lift
- K4727XLE Gray Electric Lift
- K4727XLH Gray Hydraulic Lift
- K4721XLE Ash White Electric Lift
- K4721XLH Ash White Hydraulic Lift

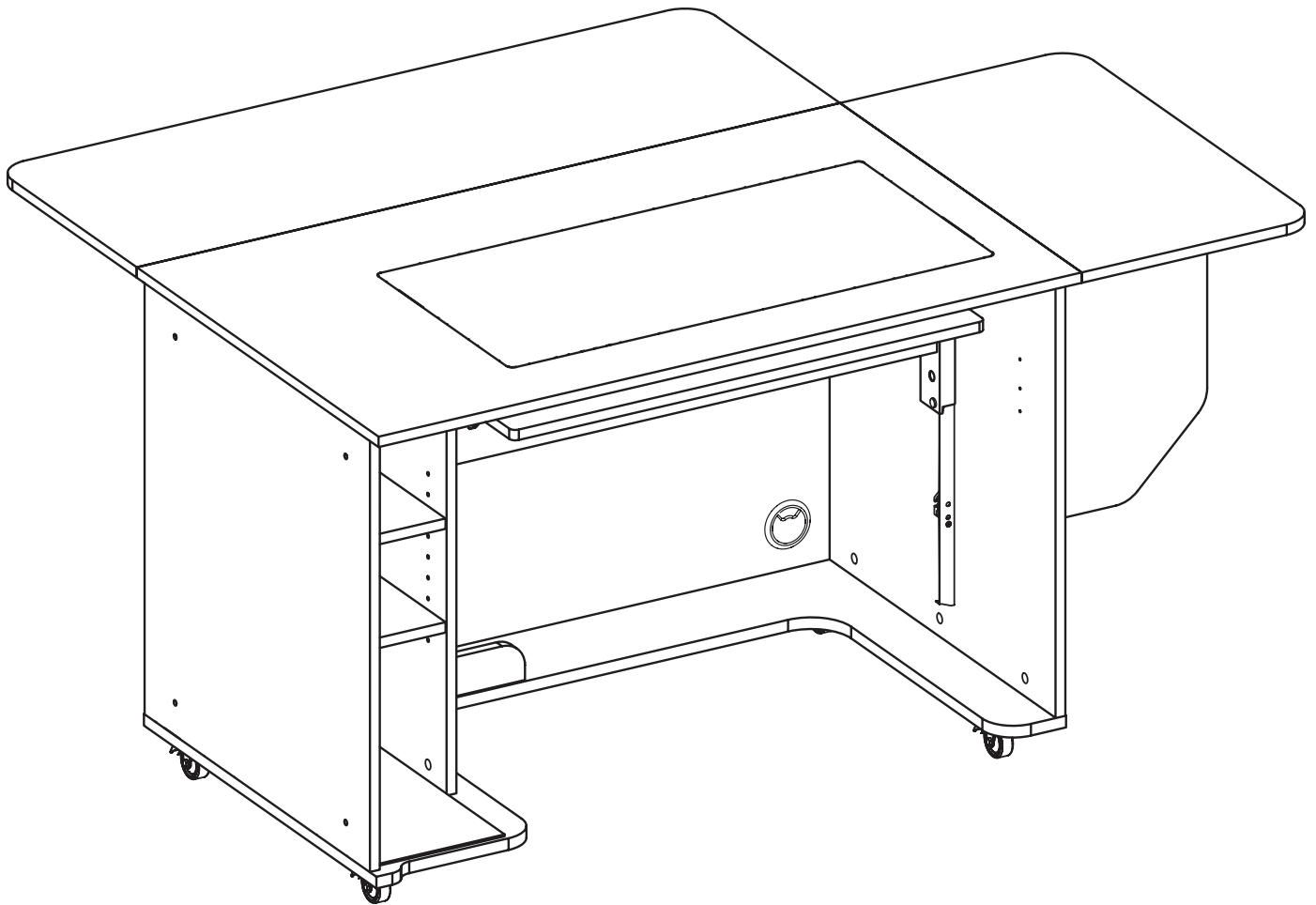

General Assembly Guidelines

1. Read the instructions carefully before beginning the assembly process to ensure proper assembly of this product. Please open and inspect the contents of box(es) to see that all parts and hardware are included.

2. Tools Required



Phillips Screwdriver ⊕



Hammer

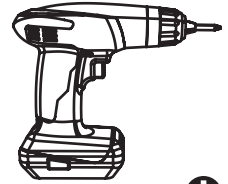

Electric Screwdriver ⊕
Torque set to 3-5

3. Understanding How the Cam Fastener Works

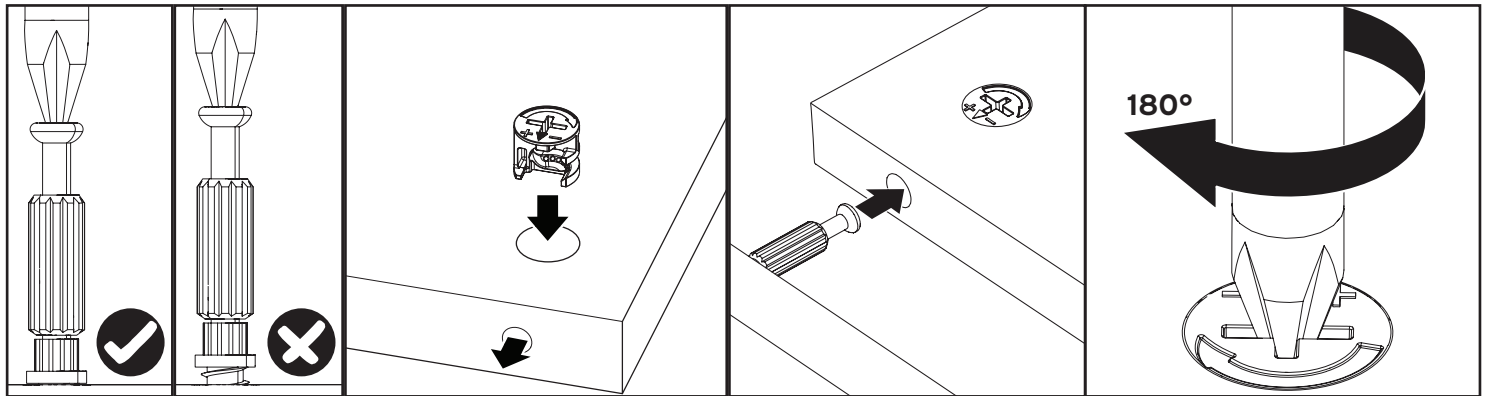

Screw cam bolts flush as illustrated.

Press cam into hole until flush with surface. The arrow direction must be in the direction of the hole.

Insert bolt through pre-drilled hole in edge of panel.

Turn clockwise to lock cam with bolt.

Tip: place a small bit of WD-40 or similar lubricant into the pre-installed cam bolt holes to help the cam bolts screw in better.

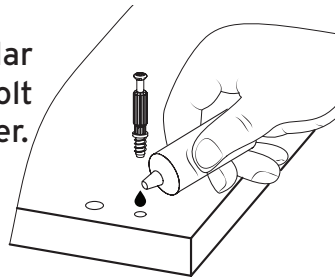

4. **Glue** provided is to secure wood dowels in place and is optional. If glue is used during assembly, locate the appropriate hole for the dowel, place a small amount of glue in the hole and insert the dowel. Wipe away excess glue immediately. It is not necessary to glue the other end of the dowel when attaching to other parts.

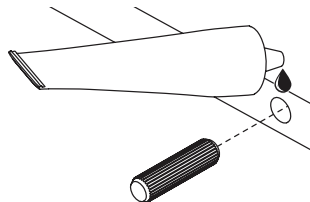

Use and Care Your cabinet normally requires a minimum amount of maintenance; however, the following points are worth noting:

Cleaning - To remove marks and enhance the surface, wipe with a gentle all-purpose cleanser. **DO NOT** use ammonia-based, harsh chemicals or abrasive cleaning agents. Wipe dry immediately.

Electrical and Hydraulic Lifts - Require annual lubrication with WD-40 or similar lubricant.

Parts List: Panels

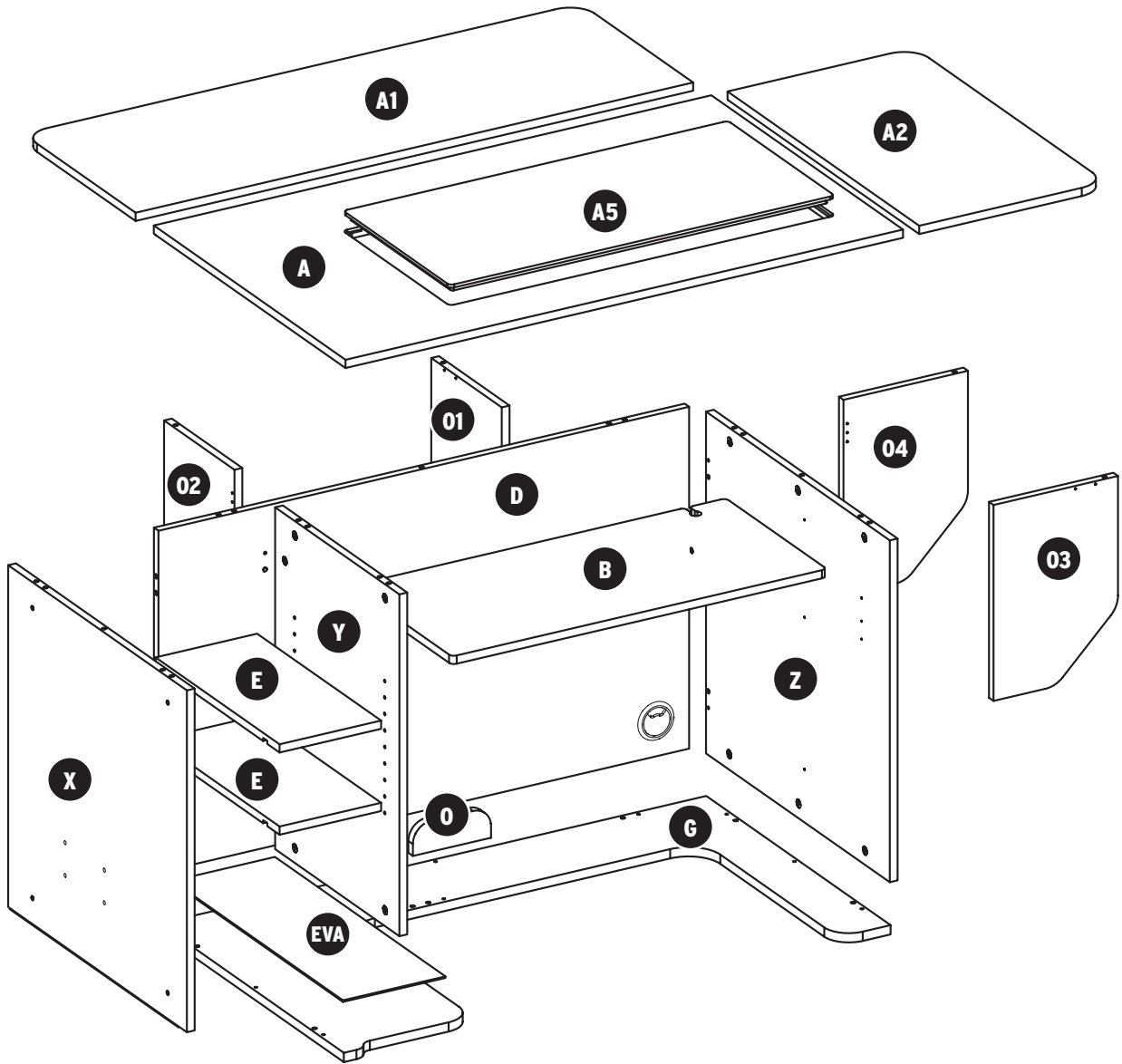

| ITEM | DESCRIPTION | QTY. | BOX | ITEM | DESCRIPTION | QTY. | BOX |
|-----------|-------------------------|------|--------|-----------|-------------------------|------|--------|
| | Hardware | 1 | 1 of 3 | D | Back Panel | 1 | 2 of 3 |
| Z | Right Panel | 1 | 1 of 3 | A | Top Panel | 1 | 2 of 3 |
| X | Left Panel | 1 | 1 of 3 | A5 | Sewing Well Cover Panel | 1 | 2 of 3 |
| Y | Center Panel | 1 | 1 of 3 | G | Bottom Panel | 1 | 2 of 3 |
| E | Shelf Panel | 2 | 1 of 3 | A1 | Rear Leaf | 1 | 3 of 3 |
| O1 | Rear Leaf Support Panel | 1 | 1 of 3 | A2 | Side Leaf | 1 | 3 of 3 |
| O2 | Rear Leaf Support Panel | 1 | 1 of 3 | | Lift and Lift Rails | 1 | 3 of 3 |
| B | Lift Platform | 1 | 1 of 3 | | | | |
| O3 | Side Leaf Support Panel | 1 | 1 of 3 | | | | |
| O4 | Side Leaf Support Panel | 1 | 1 of 3 | | | | |
| O | Insert Holder | 1 | 1 of 3 | | | | |

Parts List: Hardware

TIP: Keep all the parts in their individually labeled bags. This will make finding parts easier as you assemble your cabinet.

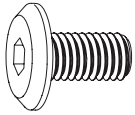

b1 8x16 Fix Bolt **x20**



b4 Post Bolt **x4**

Use this piece to secure your Adelaide Storage Cabinet (sold separately) to your Melbourne Sewing Cabinet.

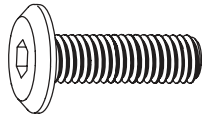

b12 6x16 Fix Bolt **x4**

For Use with Acrylic Embroidery Arm Holder, Sold Separately.

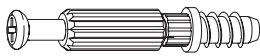

c1 6x35 Cam Bolt **x30**



c2 5/8" Cam Cover **x30**



d1 8x30 Dowel Pin **x24**

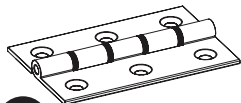

h3 Butt Hinge **x13**

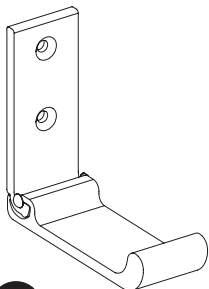

h2 Folding Hook **x2**

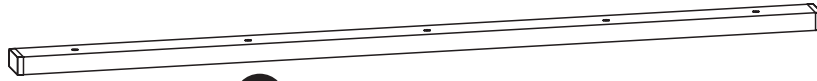

mp1 Metal Support Bar **x1**
Inside Box 2

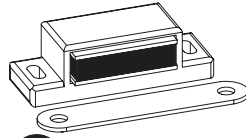

m Magnet **x4**
Catch Plate **x4**

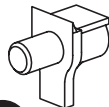

p1 Peg **x8**



s1 3.5x14 Screw **x88**



s2 3x14 Screw **x8**



s6 3.5x30 Screw **x5**

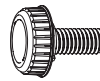

s5 Alignment Pin **x4**

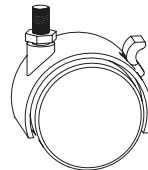

t1 Locking Caster **x2**

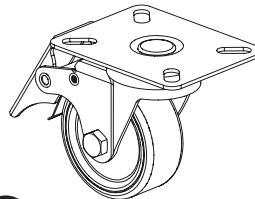

t2 Locking Plate Caster **x5**

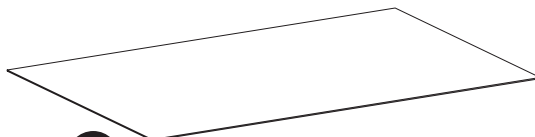

fs Adhesive Foam Sheet **x1**

Pre-installed parts

c5



Cam Lock

h4

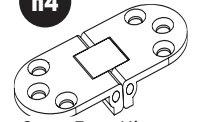

Snag Free Hinge

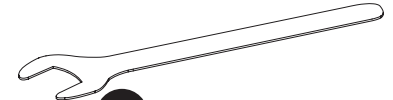

r3 14mm Wrench **x1**



a Allen Wrench **x1**



a2 4mm Allen Wrench **x1**

Parts List: Lifts

Hydraulic Lift

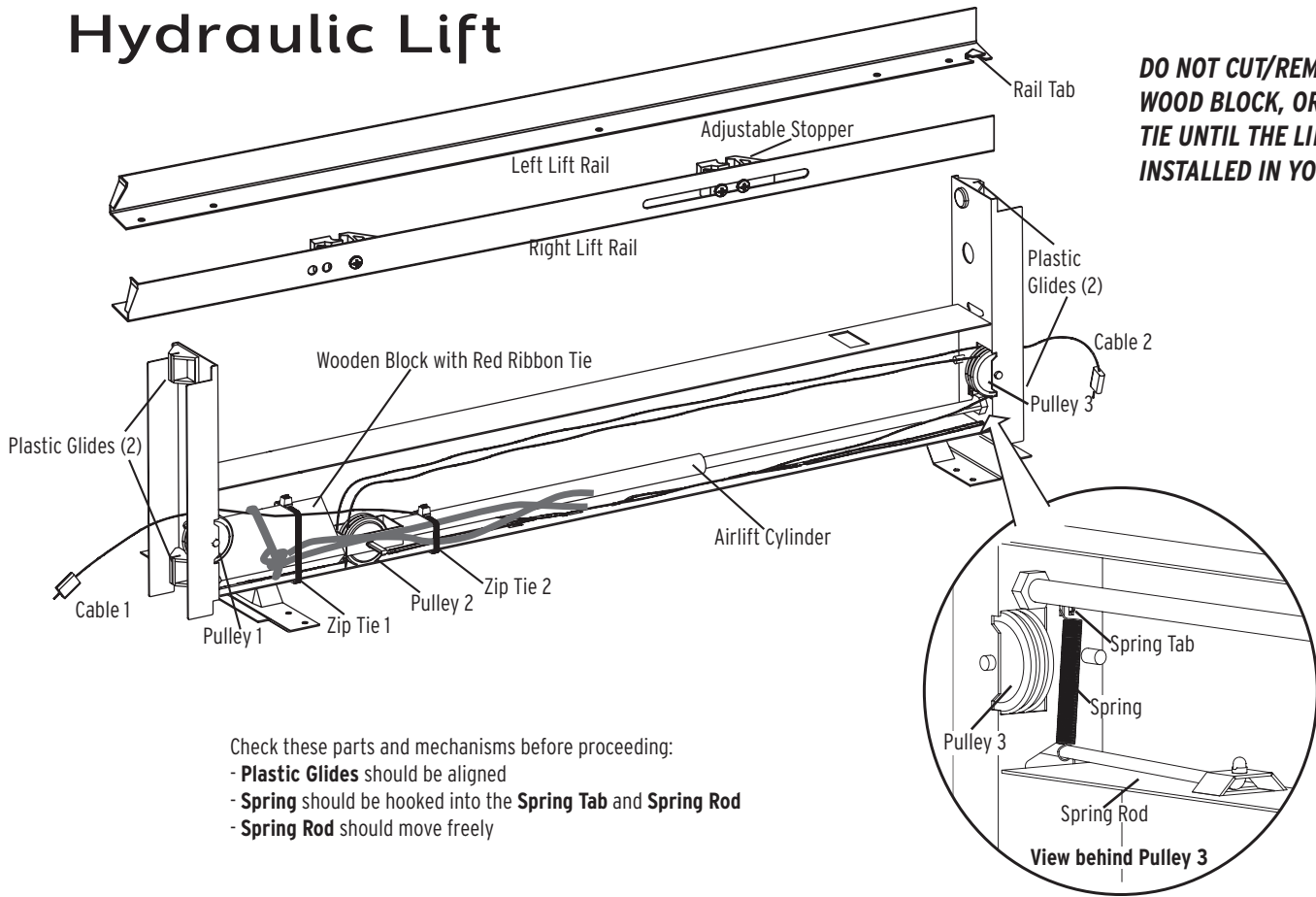

Electric Lift

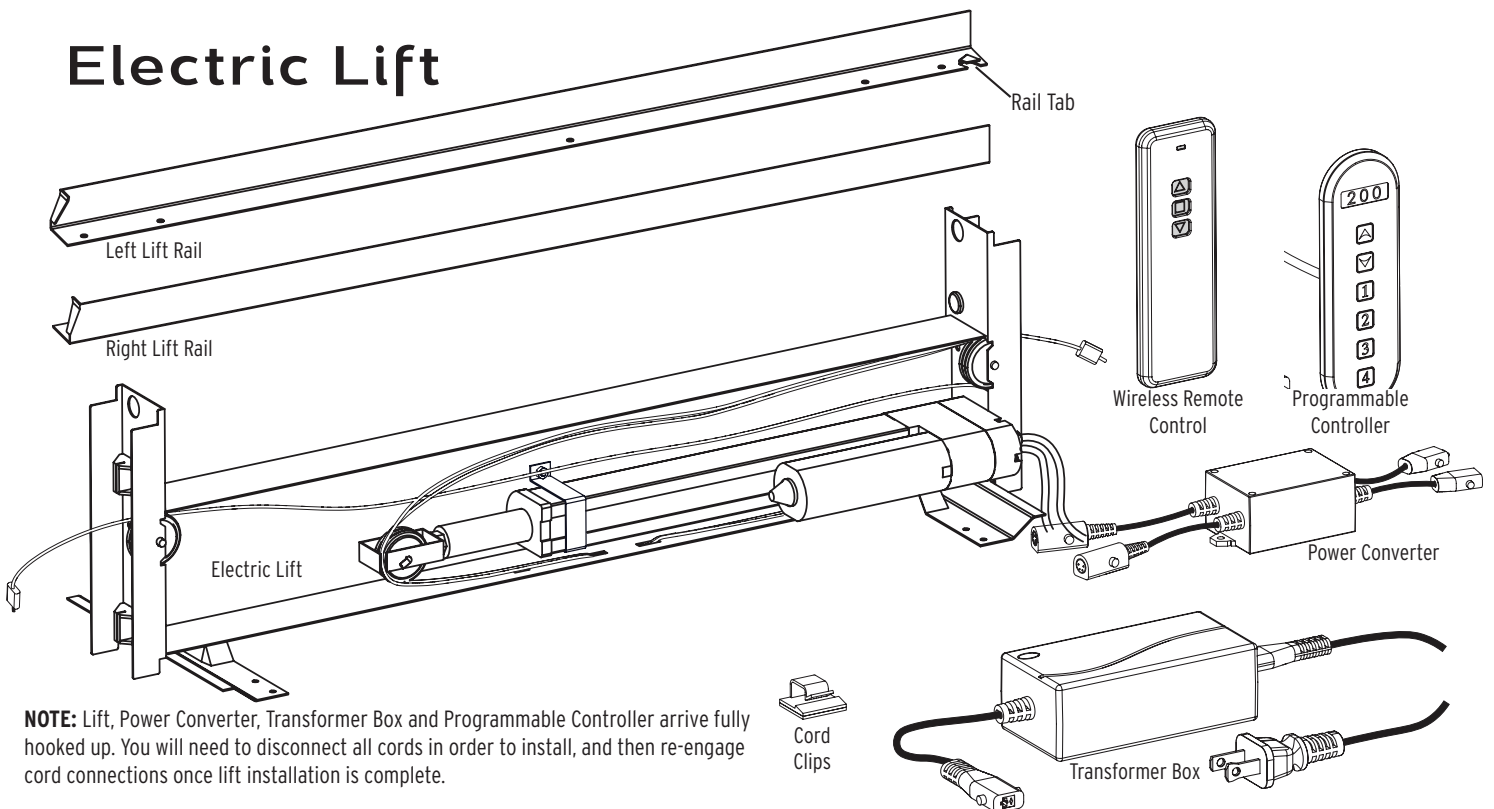

Lift Rails should be lubricated with WD-40 or a similar lubricant before assembly. Spray a small amount of lubricant on a paper towel or other lint-free cloth and wipe the rails down. Re-lubricate your lift rails annually.

Step 1: Cabinet Shell

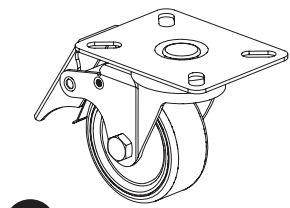

t2 Locking Plate Caster **x5**

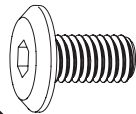

b1 8x16 Fix Bolt **x20**



a Allen Wrench **x1**

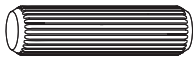

d1 8x30 Dowel Pin **x2**

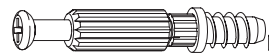

c1 6x35 Cam Bolt **x13**



c2 $\frac{5}{8}$ " Cam Cover **x2**

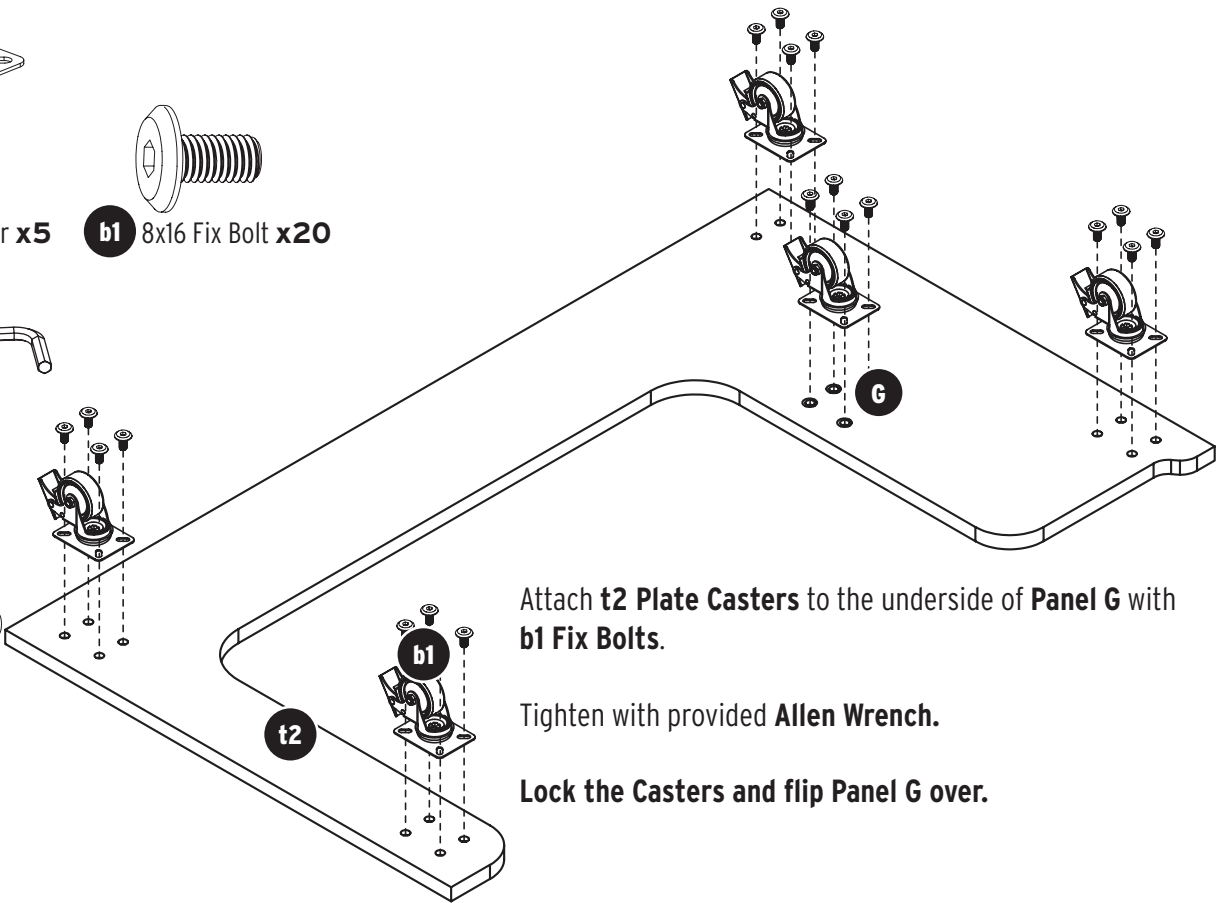

Attach **t2 Plate Casters** to the underside of **Panel G** with **b1 Fix Bolts**.

Tighten with provided **Allen Wrench**.

Lock the Casters and flip Panel G over.

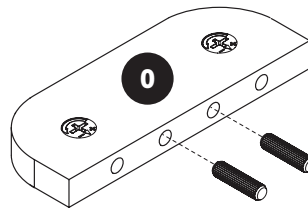

Insert **d1 Dowel Pins** into the edge of **Panel O**.

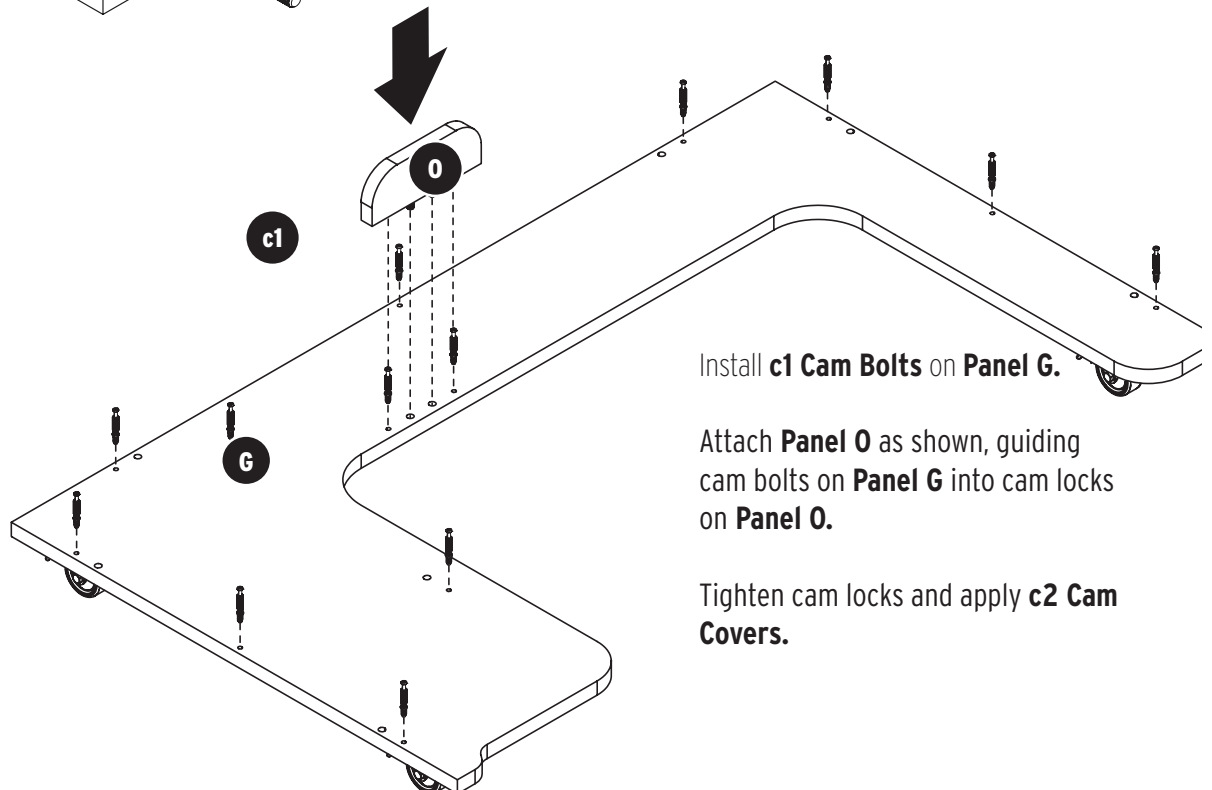

Install **c1 Cam Bolts** on **Panel G**.

Attach **Panel O** as shown, guiding cam bolts on **Panel G** into cam locks on **Panel O**.

Tighten cam locks and apply **c2 Cam Covers**.

Step 1: Cabinet Shell

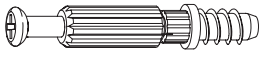

c1 6x35 Cam Bolt **x4**



d1 8x30 Dowel Pin **x14**



s1 3.5x14 Screw **x6**

Install 2 **c1** Cam Bolts and 4 **d1** Dowel Pins in Panel X.

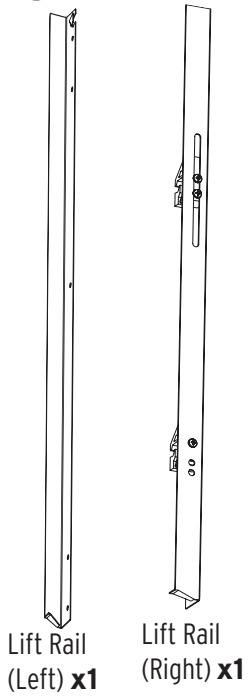

Lift Rail (Left) **x1**

Lift Rail (Right) **x1**

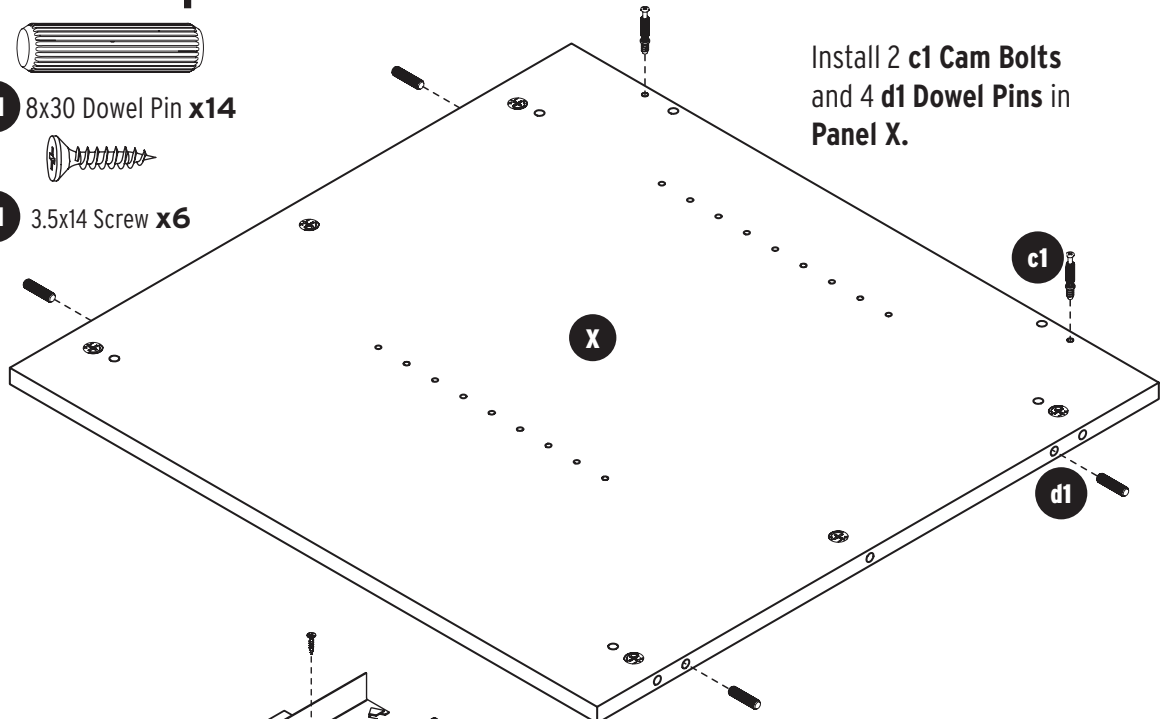

Install 6 **d1** Dowel Pins in Panel Y.

Attach **Left Lift Rail** to Panel Y using **s1** Screws.

Don't forget to wipe the lift rails with lubricant! See Page 5 for details.

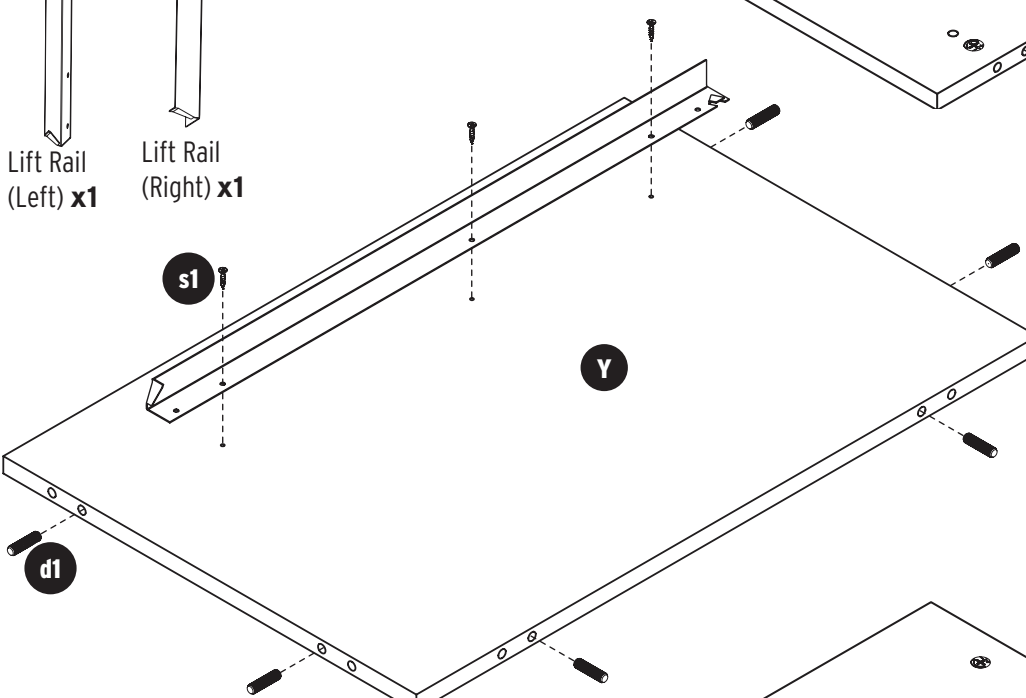

Attach **Right Lift Rail** to Panel Z with **s1** Screws.

Install 2 **c1** Cam Bolts and 6 **d1** Dowel Pins into the edges of Panel Z.

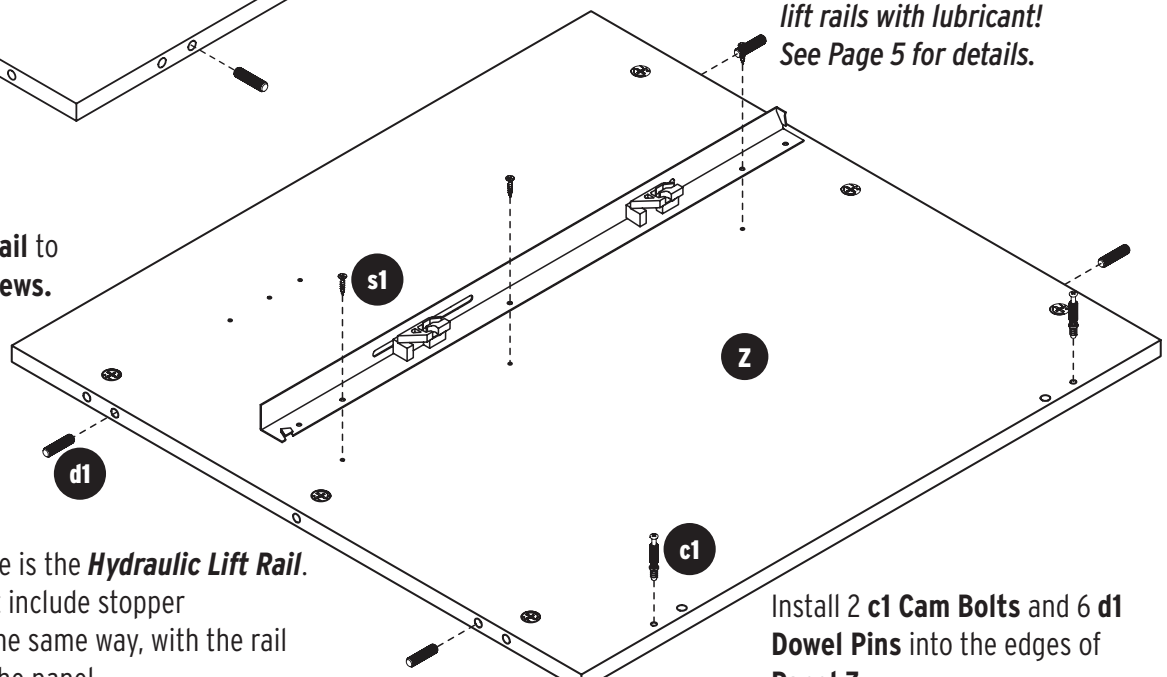

Note: The Lift Rail shown here is the **Hydraulic Lift Rail**. The Electric Lift Rail does not include stopper mechanisms, but installs in the same way, with the rail tab positioned at the top of the panel.

Step 1: Cabinet Shell

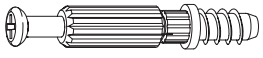

c1 6x35 Cam Bolt **x2**



d1 8x30 Dowel Pin **x8**

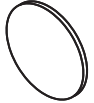

c2 5/8" Cam Cover **x2**

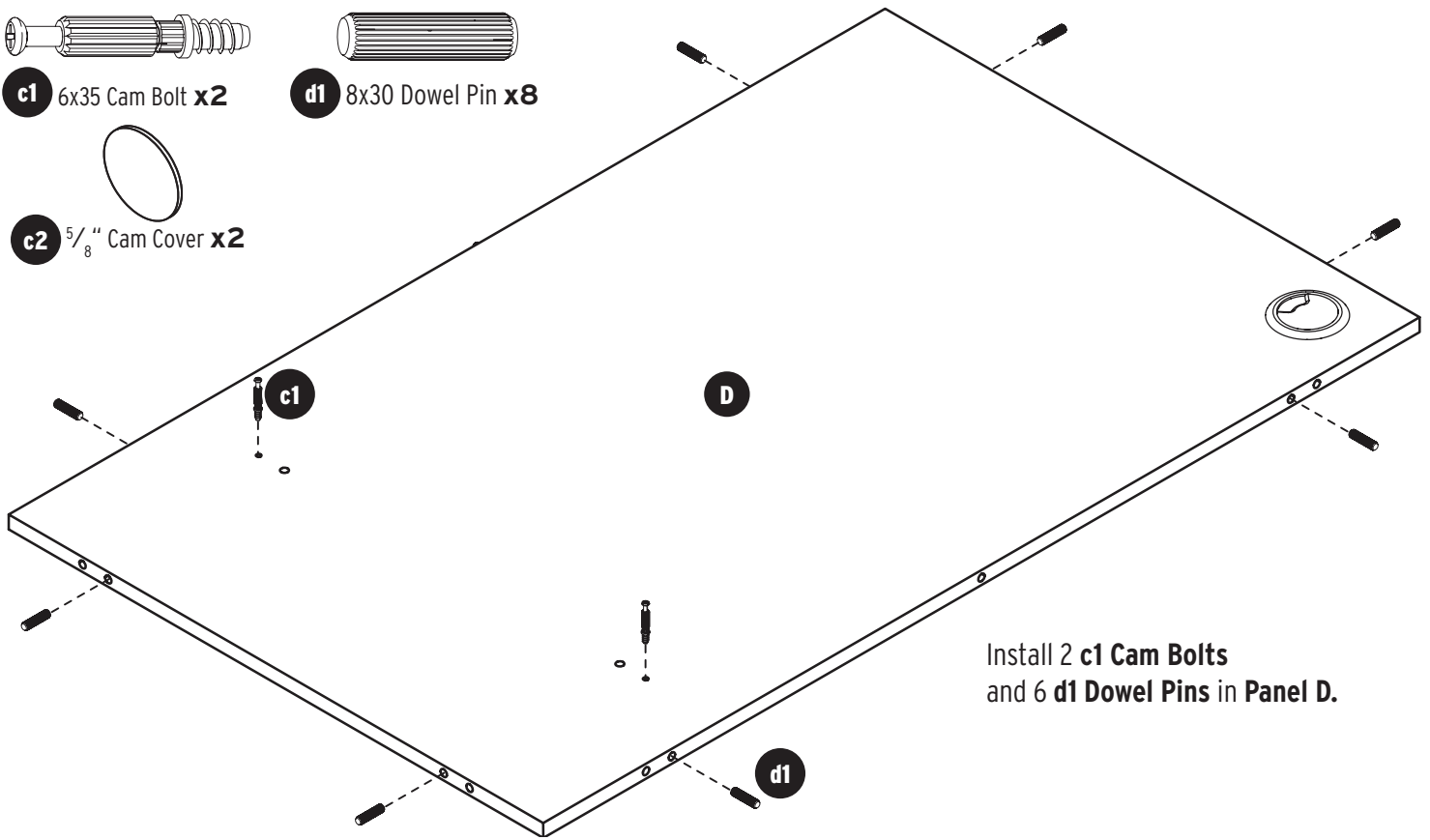

Install 2 **c1** Cam Bolts and 6 **d1** Dowel Pins in **Panel D**.

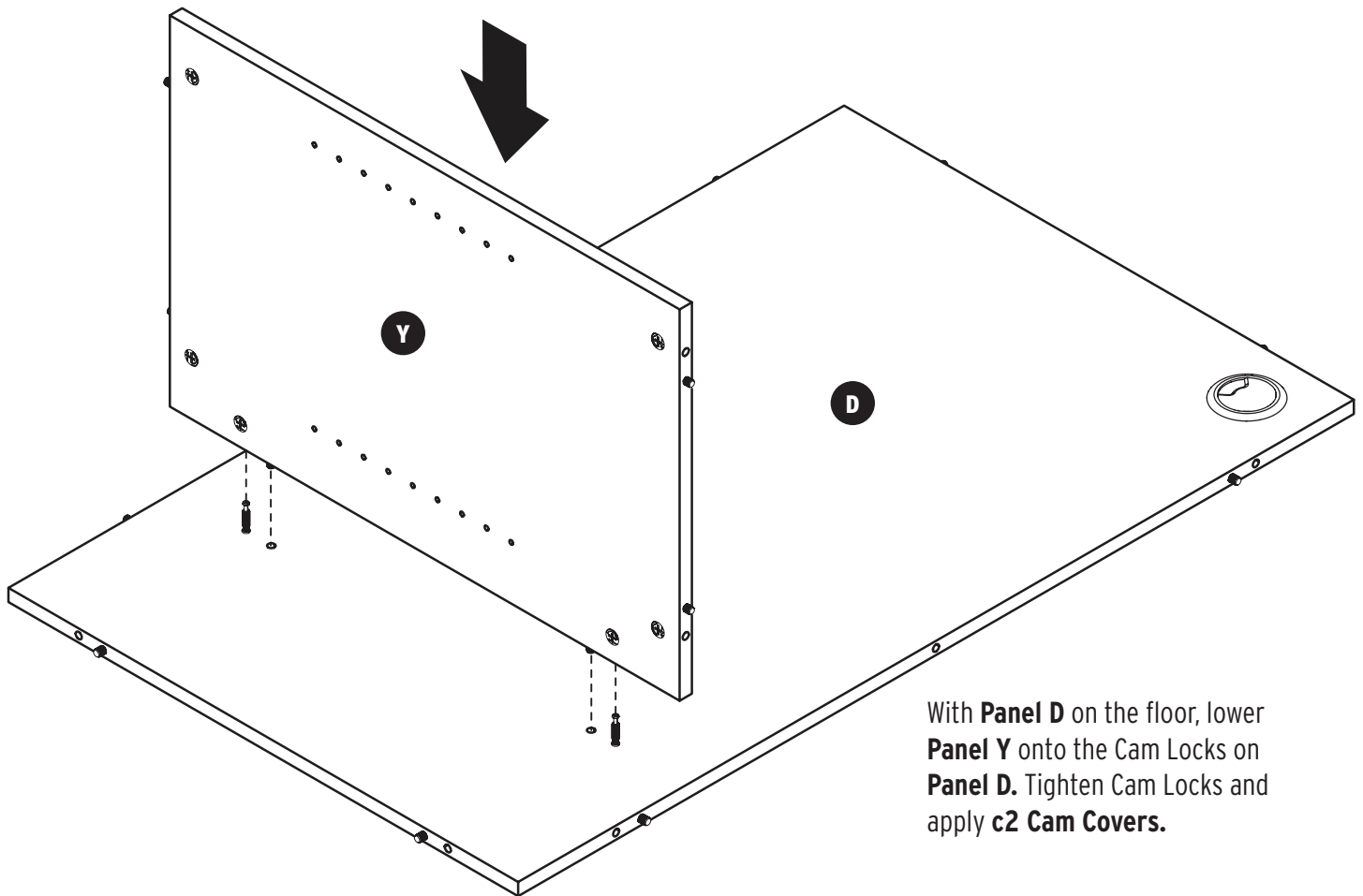

With **Panel D** on the floor, lower **Panel Y** onto the Cam Locks on **Panel D**. Tighten Cam Locks and apply **c2** Cam Covers.

Step 1: Cabinet Shell



c2 5/8" Cam Cover **x10**

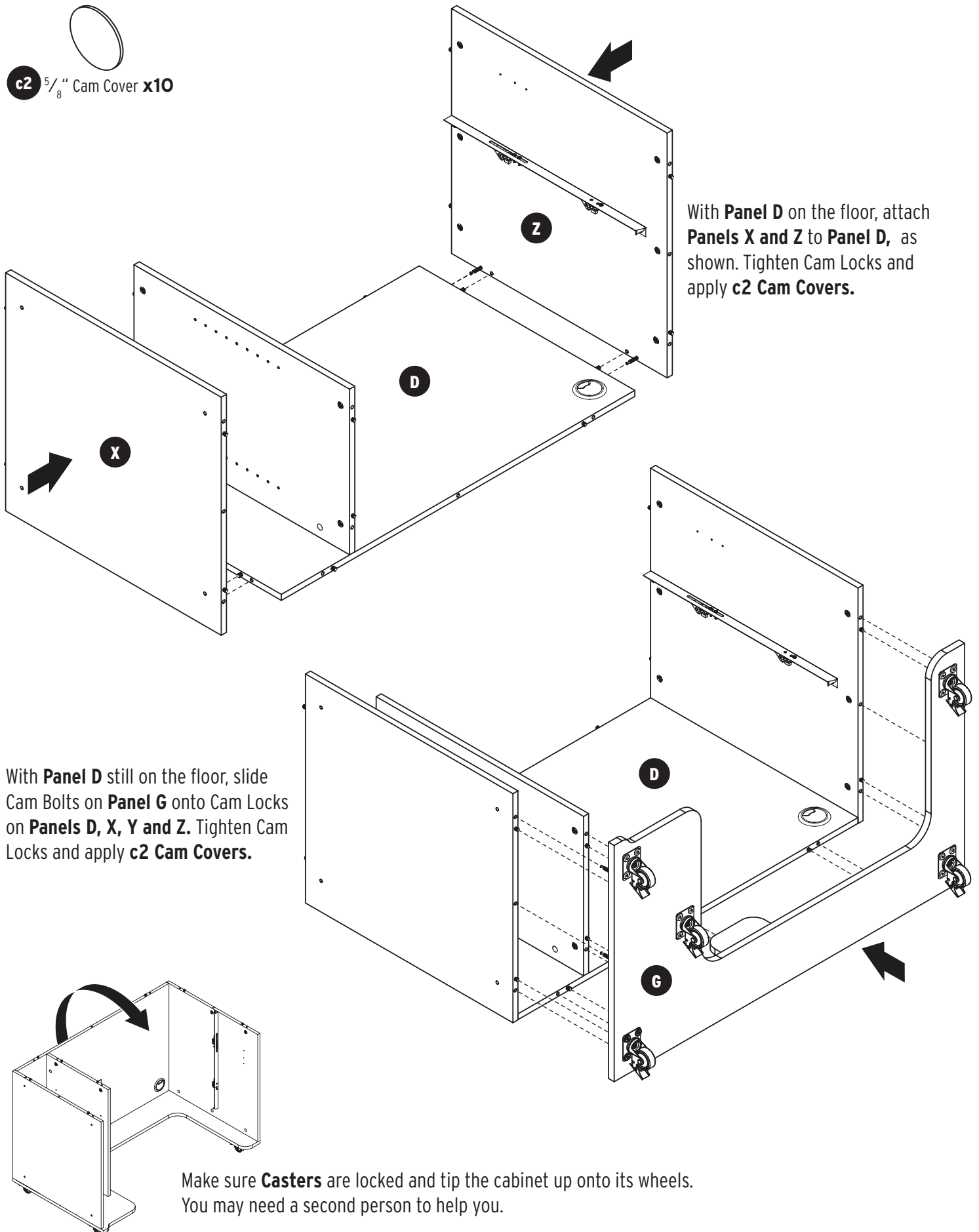

With **Panel D** on the floor, attach **Panels X and Z** to **Panel D**, as shown. Tighten Cam Locks and apply **c2 Cam Covers**.

With **Panel D** still on the floor, slide Cam Bolts on **Panel G** onto Cam Locks on **Panels D, X, Y and Z**. Tighten Cam Locks and apply **c2 Cam Covers**.

Make sure **Casters** are locked and tip the cabinet up onto its wheels. You may need a second person to help you.

Step 2: Lift Installation

Hydraulic Lift Installation: Page 11

Electric Lift Installation: Page 13

Step 2a: Hydraulic Lift Installation

HYDRAULIC LIFT INSTALLATION WARNING:

DO NOT remove the small wooden block from the Lift until assembly is complete. If the block is removed or falls out before lift assembly is complete, the cables will retract, making installation more difficult. If the block falls out before complete assembly, please call Customer Service at 1-800-533-7347, ext. 1 for assistance, or visit www.arrowsewing.com/assembly and find the "Alternate Sewing Lift Installation" video.

For video instructions, please visit www.arrowsewing.com/assembly and find the "How to Install Your Hydraulic Lift" video.

This illustration shows the back view of the **Lift**. Notice the wooden block, red ribbon, and zip ties; the wooden block holds the piston in place so that the cables can be easily handled and inserted into the **Lift Rails** installed on your cabinet. Do not pull on the red ribbon or remove the zip ties just yet!

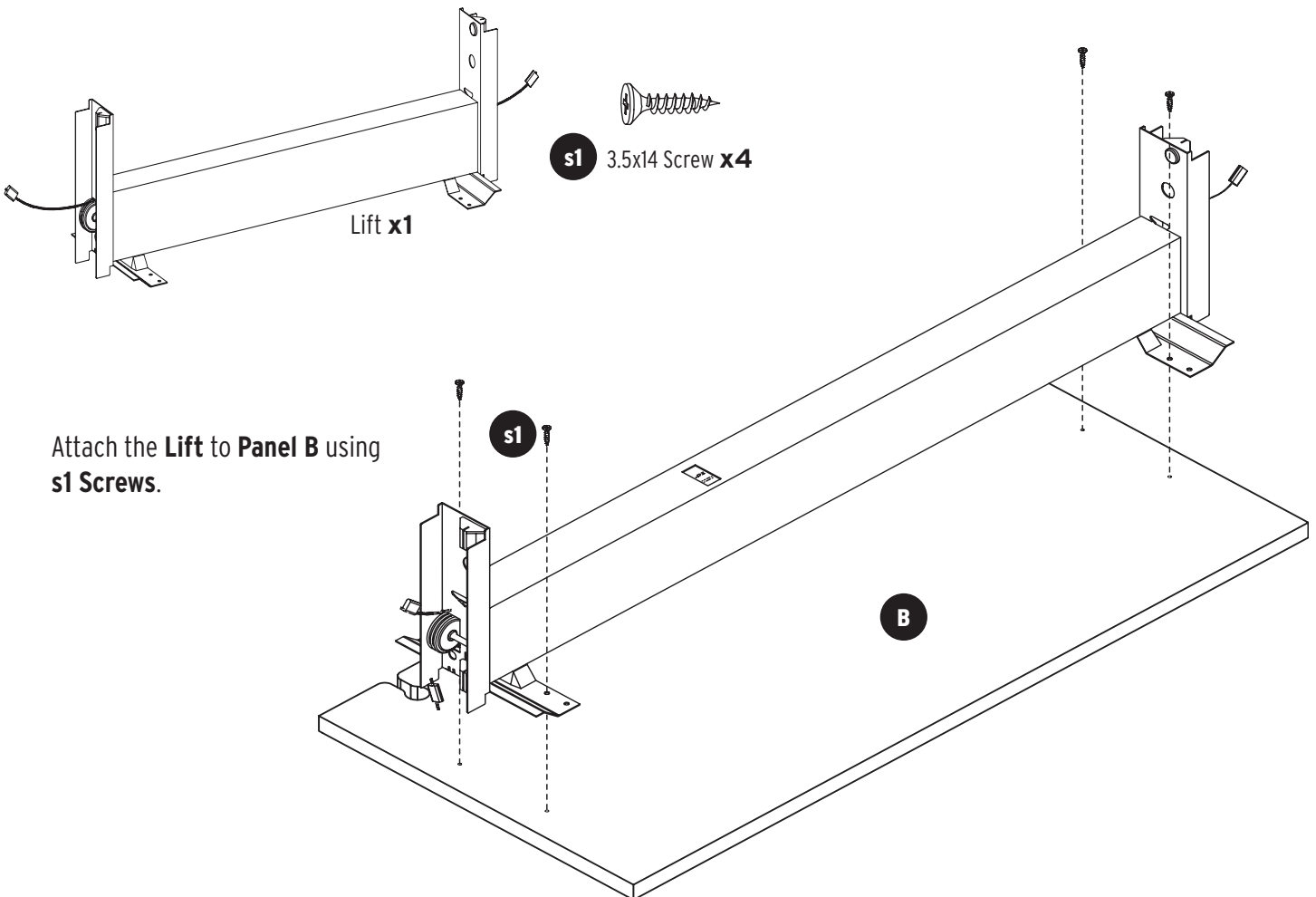
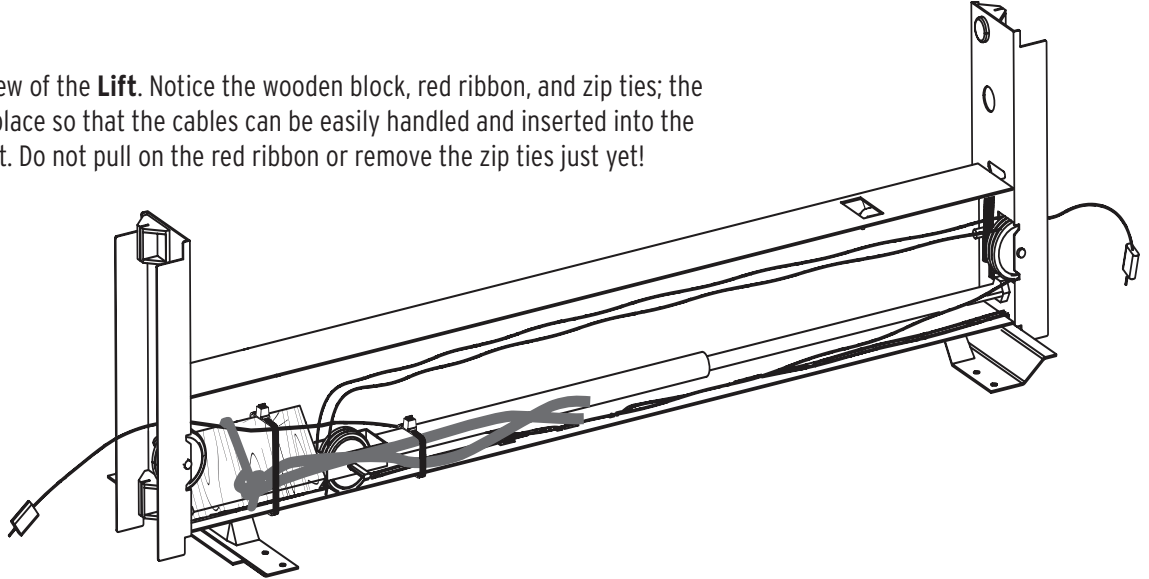

Attach the **Lift** to **Panel B** using **s1** Screws.

Step 2a: Hydraulic Lift Installation

Guide **Lift** onto **Lift Rails** using plastic guides. Insert ends of cable into rail tabs; make sure the cable is hooked into the rail tabs on both sides.

Cut the zip ties on the lift, but DO NOT remove the block yet.

Lower the **Lift** to first lock position and by pushing firmly on the platform. Keep pushing until you hear a **CLICK!** You may now remove the wooden block. It may fall out on its own once your lift is in position, If it does not, pull on the red ribbon to dislodge. **DO NOT ADJUST LIFT POSITION until the top is installed**, or you risk the Lift coming out and cables becoming disengaged.

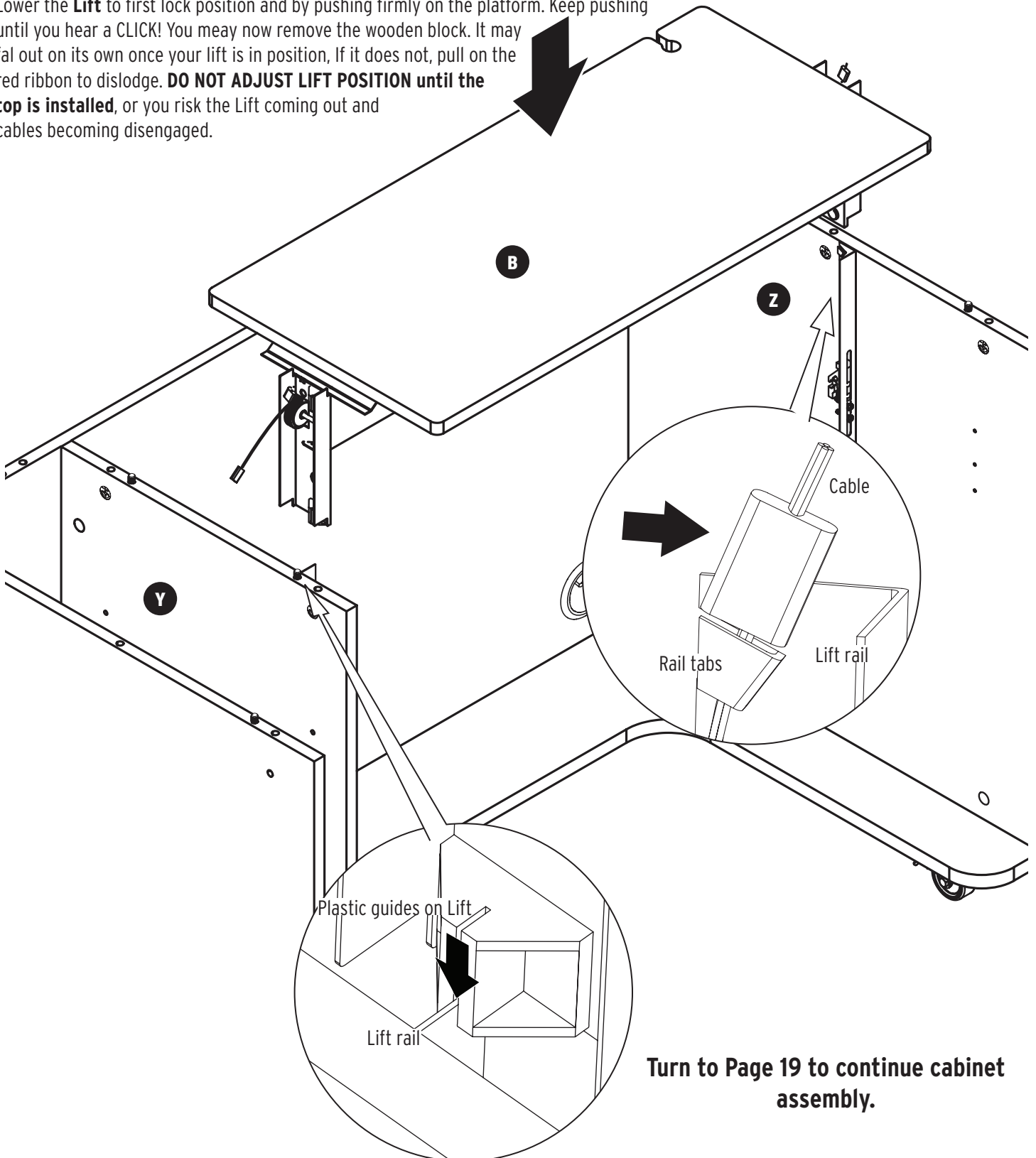

Turn to Page 19 to continue cabinet assembly.

REMINDER: Our Customer Service Team is available for any assembly related questions. Please call 1-800-533-7347, ext. 1 to speak with an Assembly Expert.

Step 2b: Electric Lift Installation

NOTE: This illustration depicts the BACK of your lift.

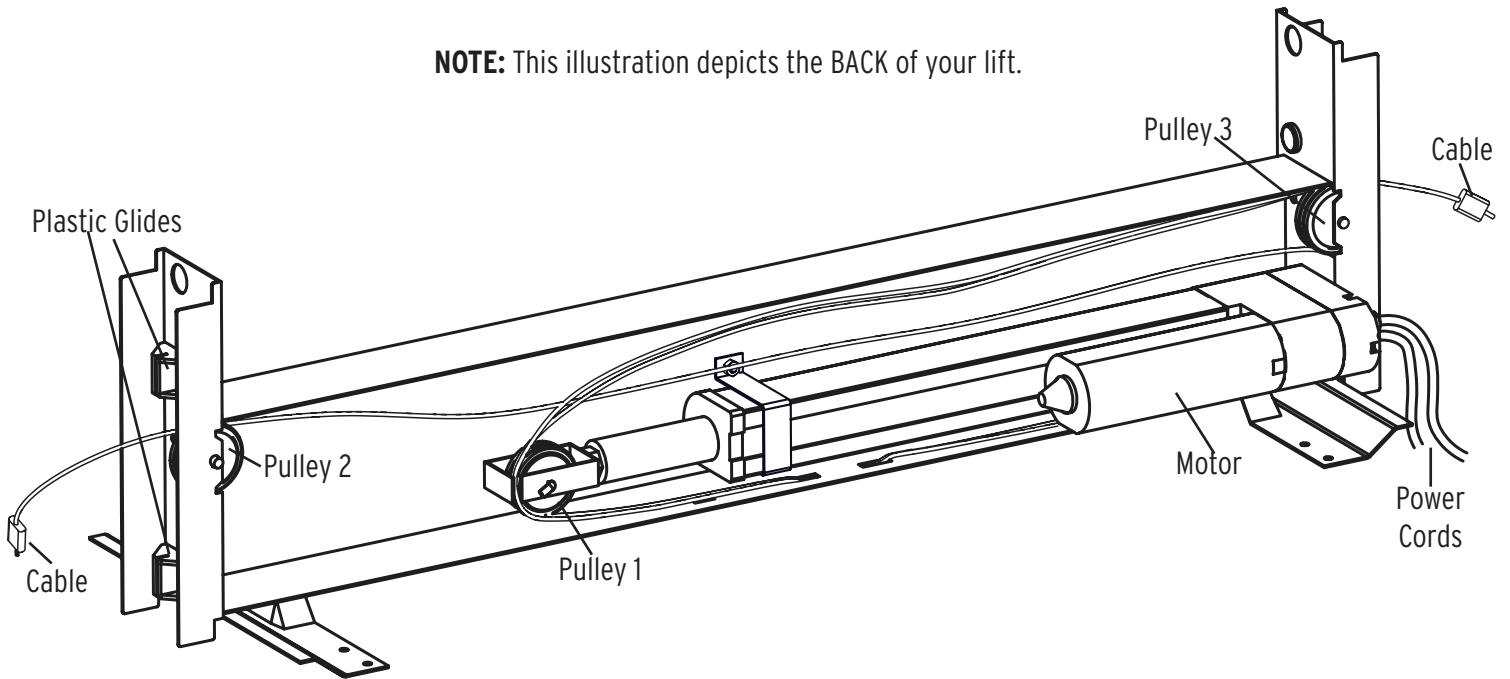

Attach the **Lift** to **Panel B** using **s1** Screws.

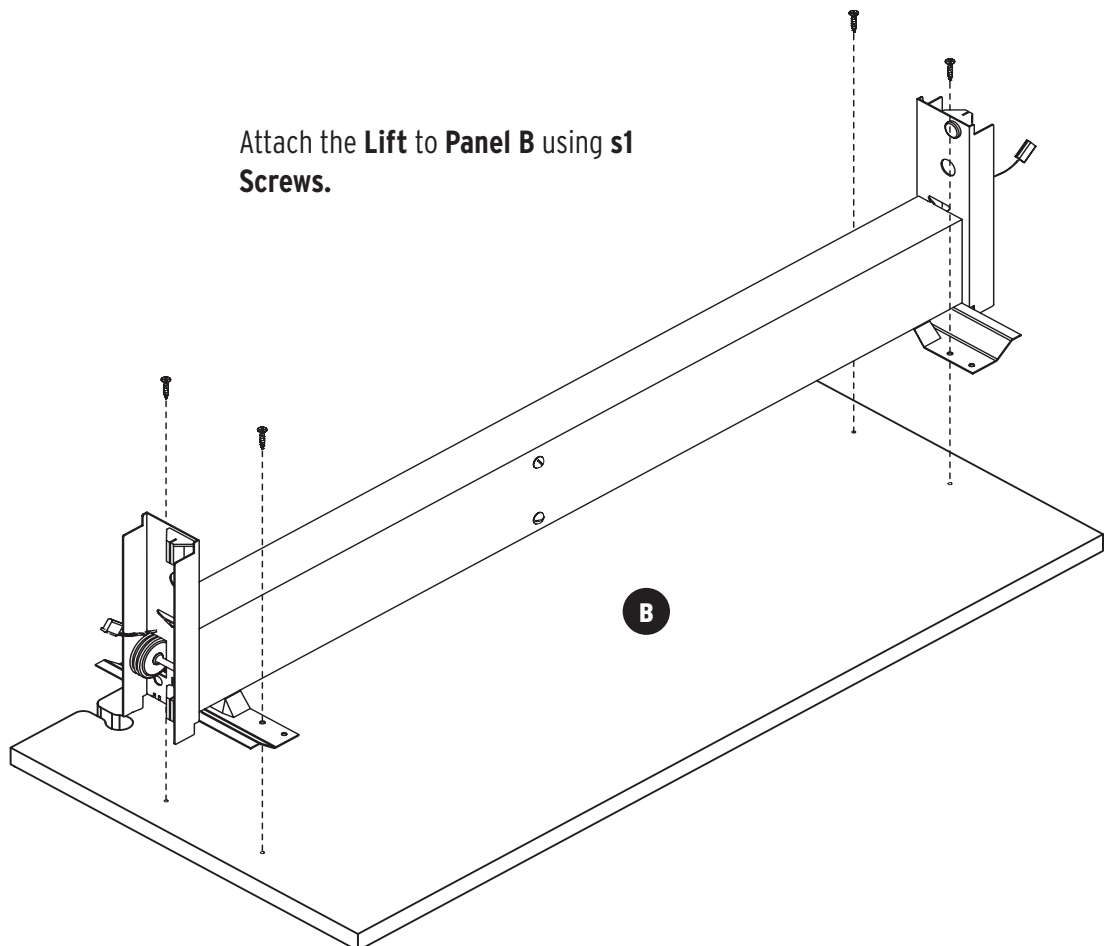

Step 2b: Electric Lift Installation

Pull the Cable as far out as it will go.

Guide **Lift** onto **Lift Rails** using plastic guides. Insert ends of cable into rail tabs; make sure the cable is hooked into the rail tabs on both sides.

REMINDER: Our Customer Service Team is available for any assembly related questions. Please call 1-800-533-7347, ext. 1 to speak with an Assembly Expert.

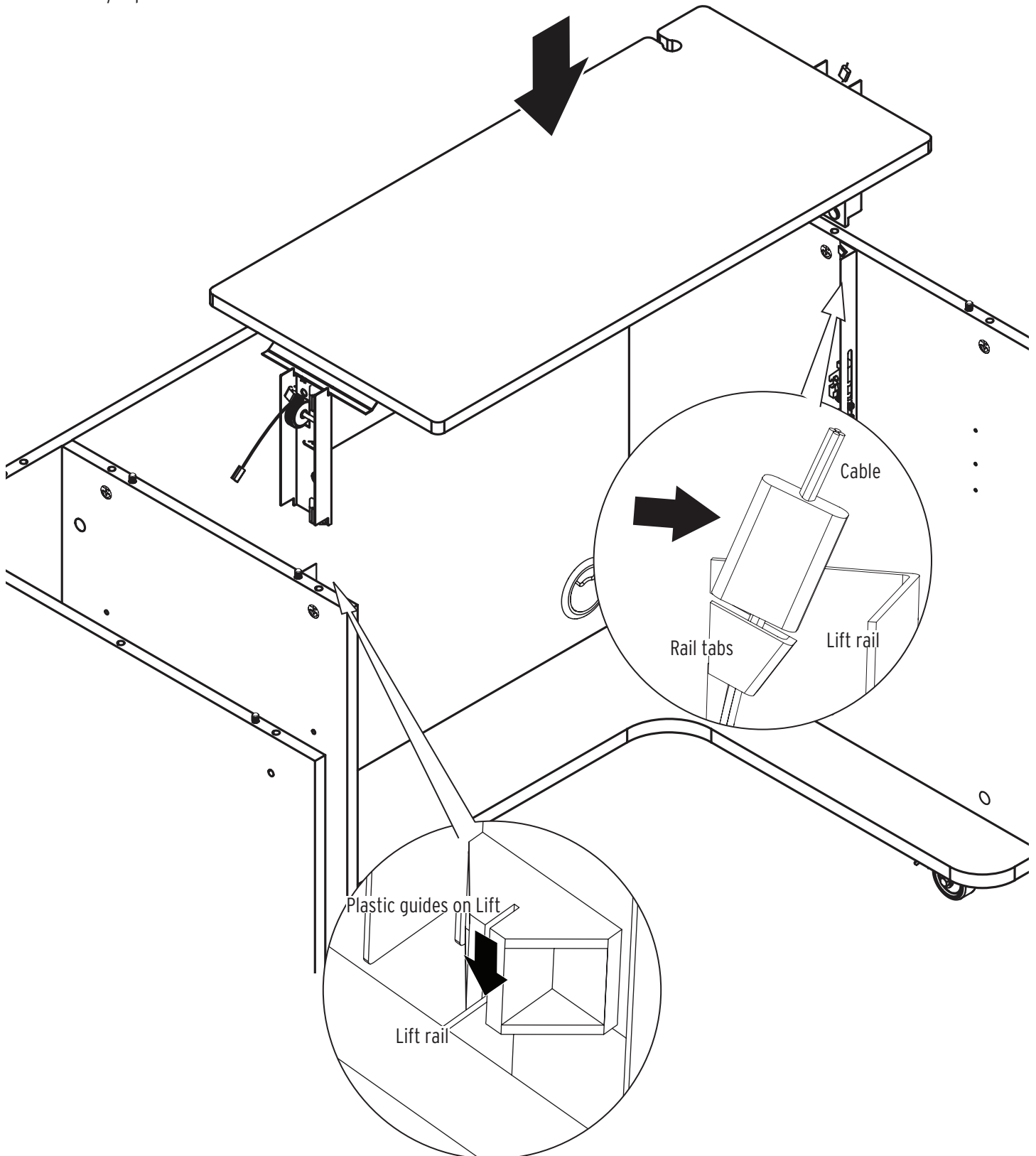

Step 2c: Electric Lift Cord Management

To control the cords coming from your electric lift, twist them together and feed them through the cord port in your cabinet's lower right back corner. DO NOT USE Cord Clips on the cords coming from the Electric Lift.

Attach the Programmable Controller with the screws provided. Scan this QR code for a printable template:



OPTIONAL: You may use Cord Clips on the wire coming from the Programmable Controller, as shown below.

NOTE: When securing cords with Cord Clips, be careful to keep cords from crossing over the lift rails.

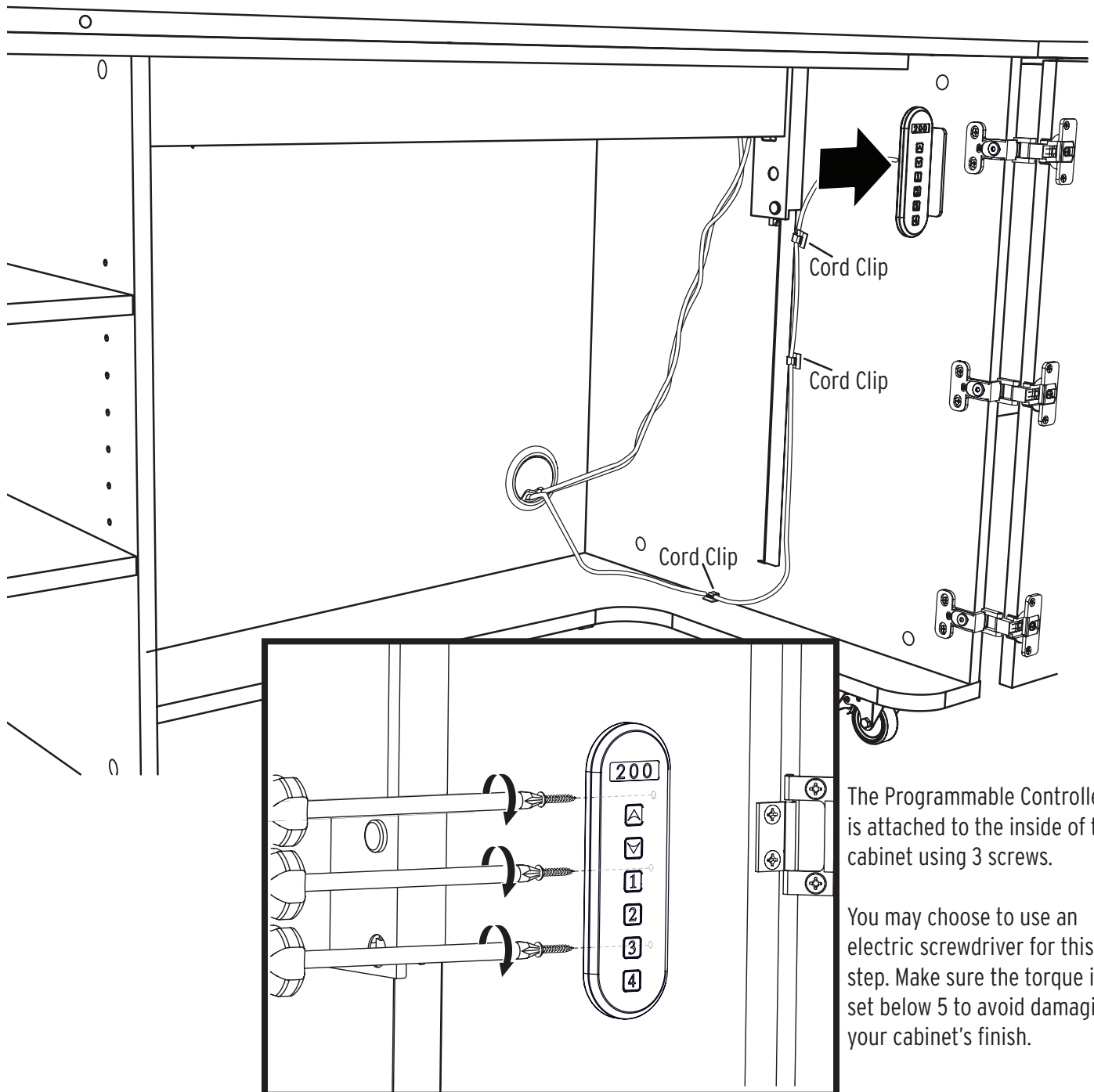

The Programmable Controller is attached to the inside of the cabinet using 3 screws.

You may choose to use an electric screwdriver for this step. Make sure the torque is set below 5 to avoid damaging your cabinet's finish.

Step 2c: Electric Lift Cord Management

Carefully feed the twisted cords from the Electric Lift and the Programmable Controller through the Cord Port and plug them in to the Power Converter.

NOTE: Each cord and cord receptacle has a different pin pattern, making it easy to match the cords to the Power Converter.

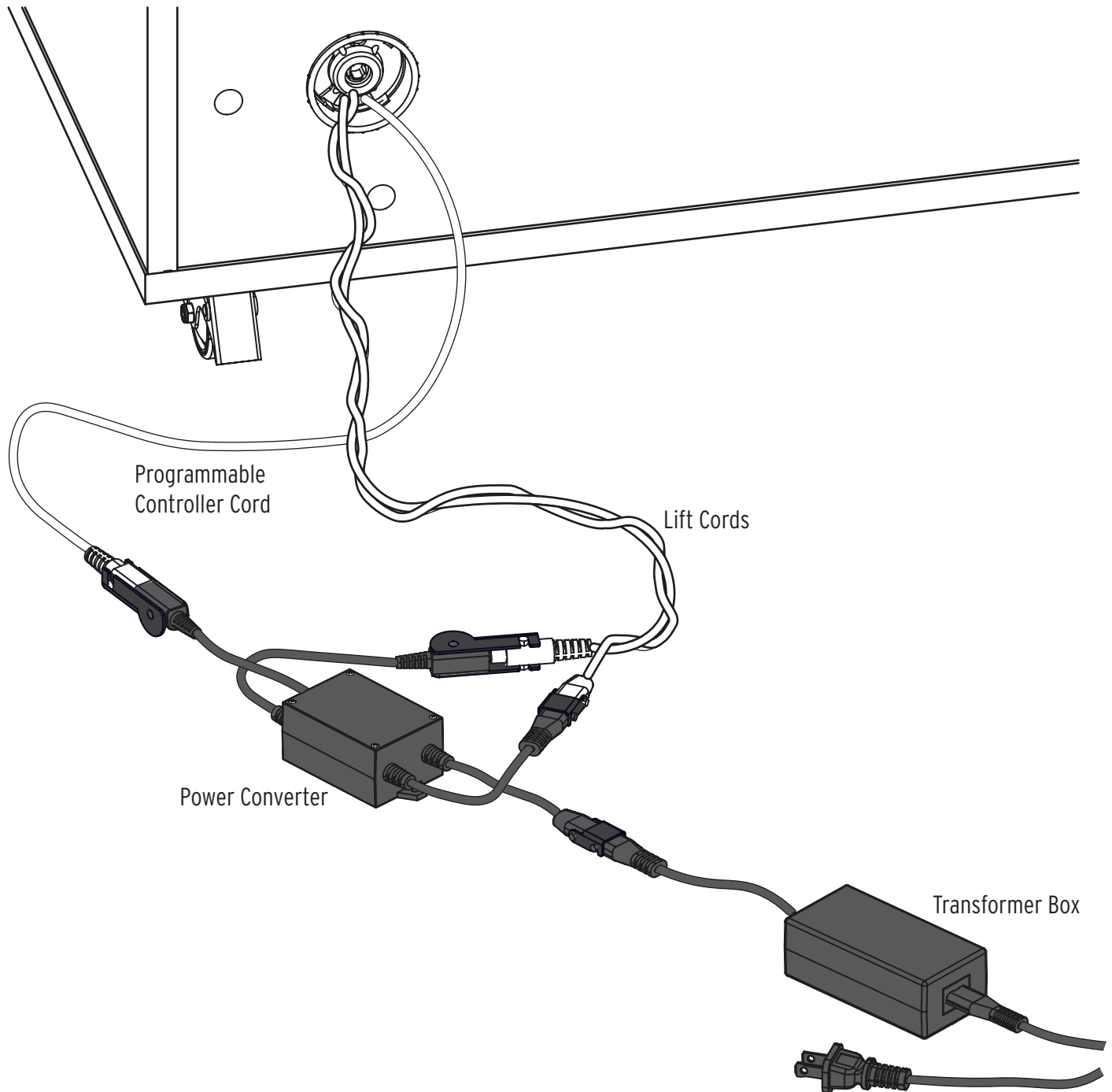

Step 2d: Electric Lift Programming and Use

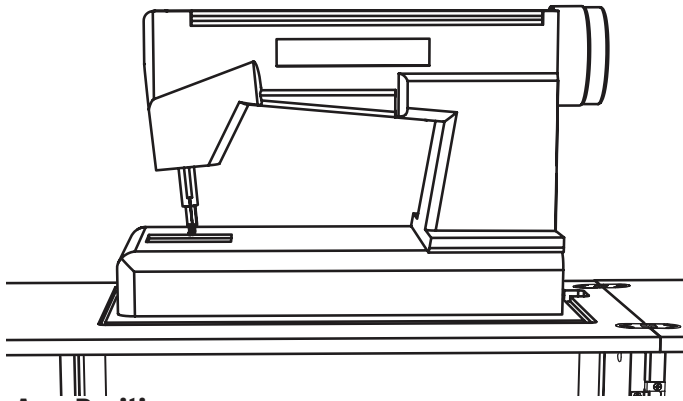

Free Arm Position:

Also known as “tabletop sewing,” this is the favored sewing position to use for hems, cuffs, and other small, curved pieces.

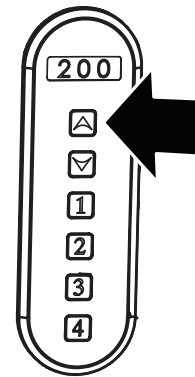

Press and hold the UP button on your controller to position your lift platform in the uppermost position. Press and hold the preset position of your choice for 5 seconds. Free Arm Position is now pre-set.

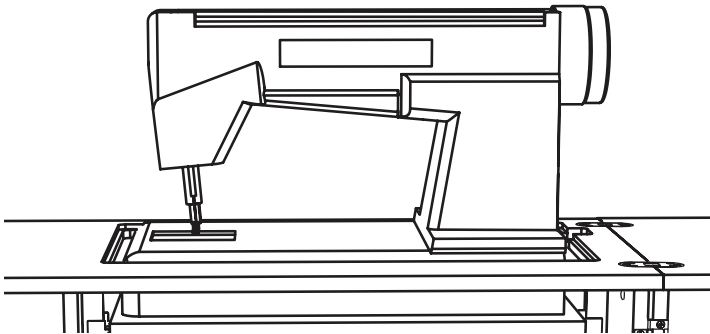

Flatbed Position:

Flatbed Position is perfect for sewing larger, heavier projects and is the most comfortable way to sew. Add a custom acrylic insert for a custom fit to your specific machine and cabinet to experience a truly ergonomic sewing session.

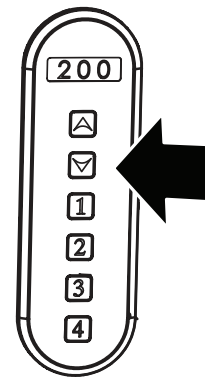

Press and hold the DOWN button on your controller until the throat plate on your machine is level with the tabletop. Press and hold the preset position of your choice for 5 seconds. Flat Bed Position is now pre-set.

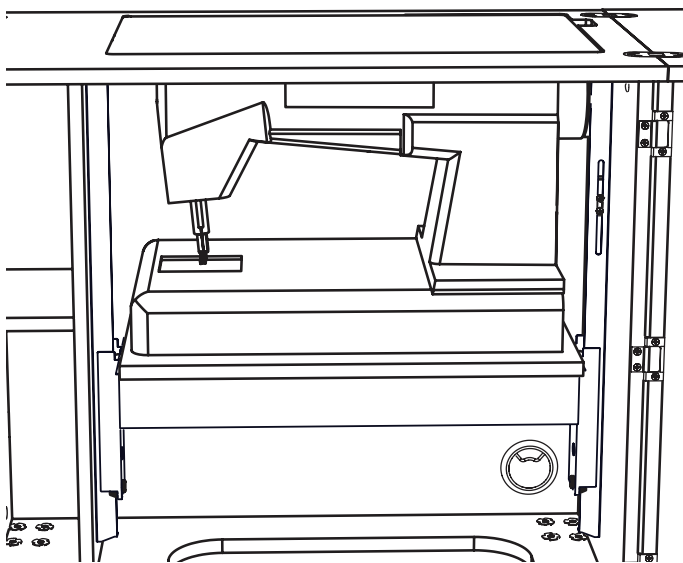

Storage Position:

Your sewing machine is now safely stored in the belly of your sewing cabinet! If your cabinet includes a sewing well cover, you may place that over your sewing well and use your cabinet as a desk.

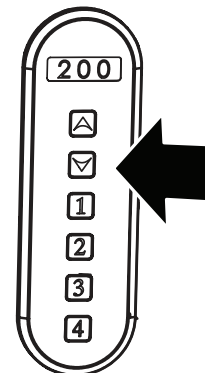

Press and hold the DOWN button on your controller until the platform is completely lowered. Press and hold the preset position of your choice for 5 seconds. Storage Position is now pre-set.

NOTE: Use your preset functions your own way! You can set Flatbed Position for multiple machines or preset positions for Storage or Free Arm positions. The choice is yours!

Step 2d: Electric Lift Programming and Use

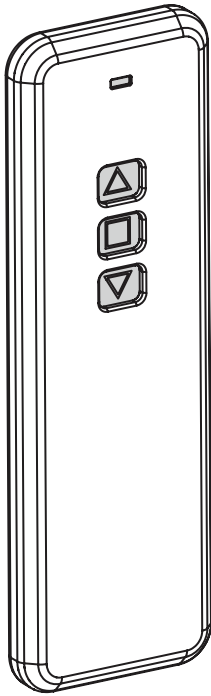

Use your Remote Control to move your machine up and down from across the room! Press the UP or DOWN button to move the lift, and the center STOP button to stop.

Using the control pad or the remote control, move the lift back into the flatbed position. Check to make sure that your machine is now sitting at the right height for comfortable, ergonomic flatbed sewing and adjust as necessary.

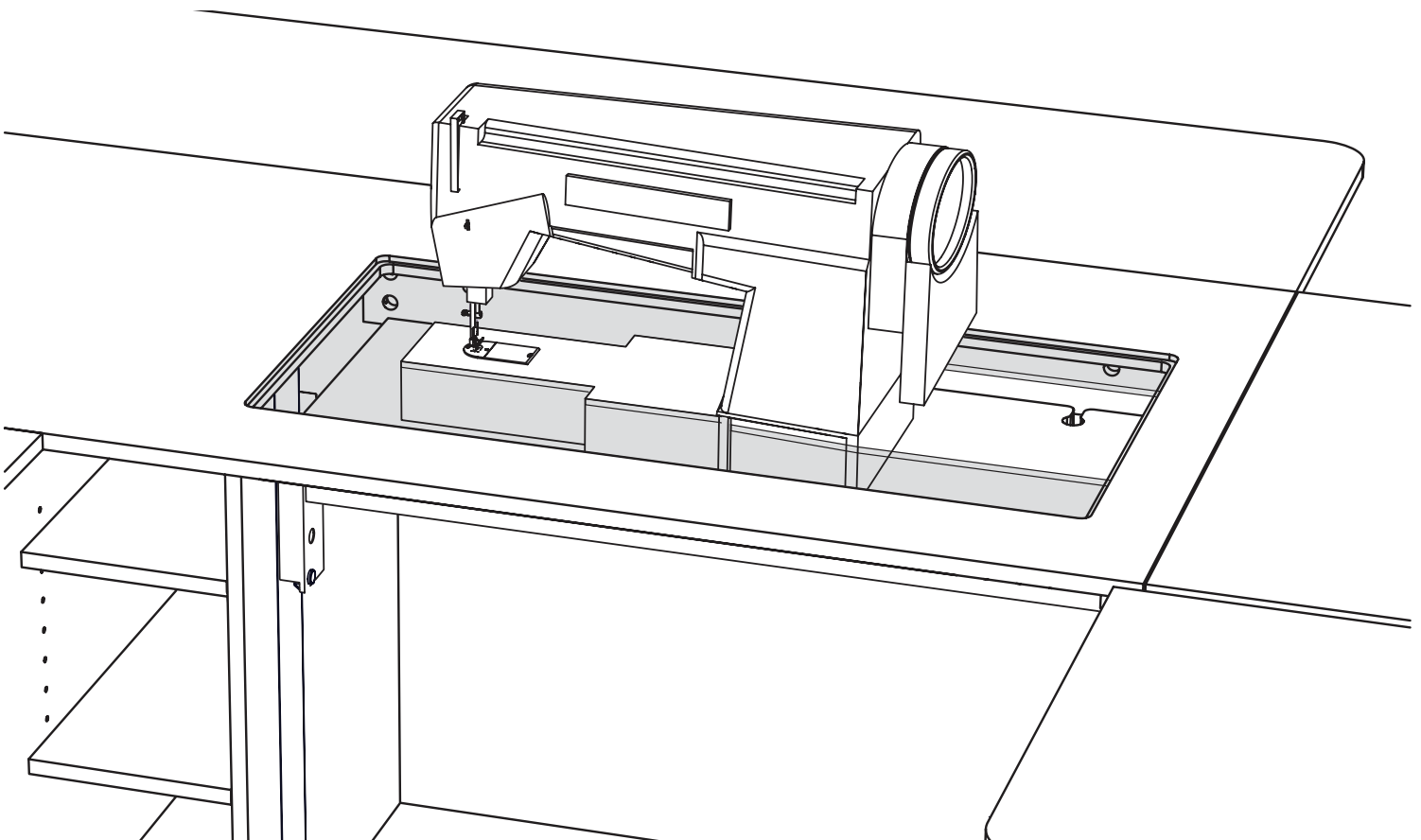

Place your Custom Acrylic Insert in the sewing well, fitting it around your machine. You now have a perfectly comfortable flat bed sewing cabinet! Say goodbye to hunched shoulders, tired wrists, and an aching back and hello to HAPPY SEWING!

To place an order for your own Custom Acrylic Insert, visit us online at ArrowSewing.com, or contact Arrow Sewing Customer Service at 1-800-533-7347 ext 1 during normal business hours.

Step 3: Top and Leaves

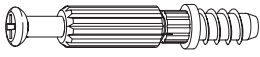

c1 6x35 Cam Bolt **x11**



mp1 Metal Support Bar **x1**



s6 3.5x30 Screw **x5**

Attach **c1 Cam Bolts** to the underside of **Panel A**.

Attach **Metal Support Bar** to **Panel A** using **s6 Screws**.

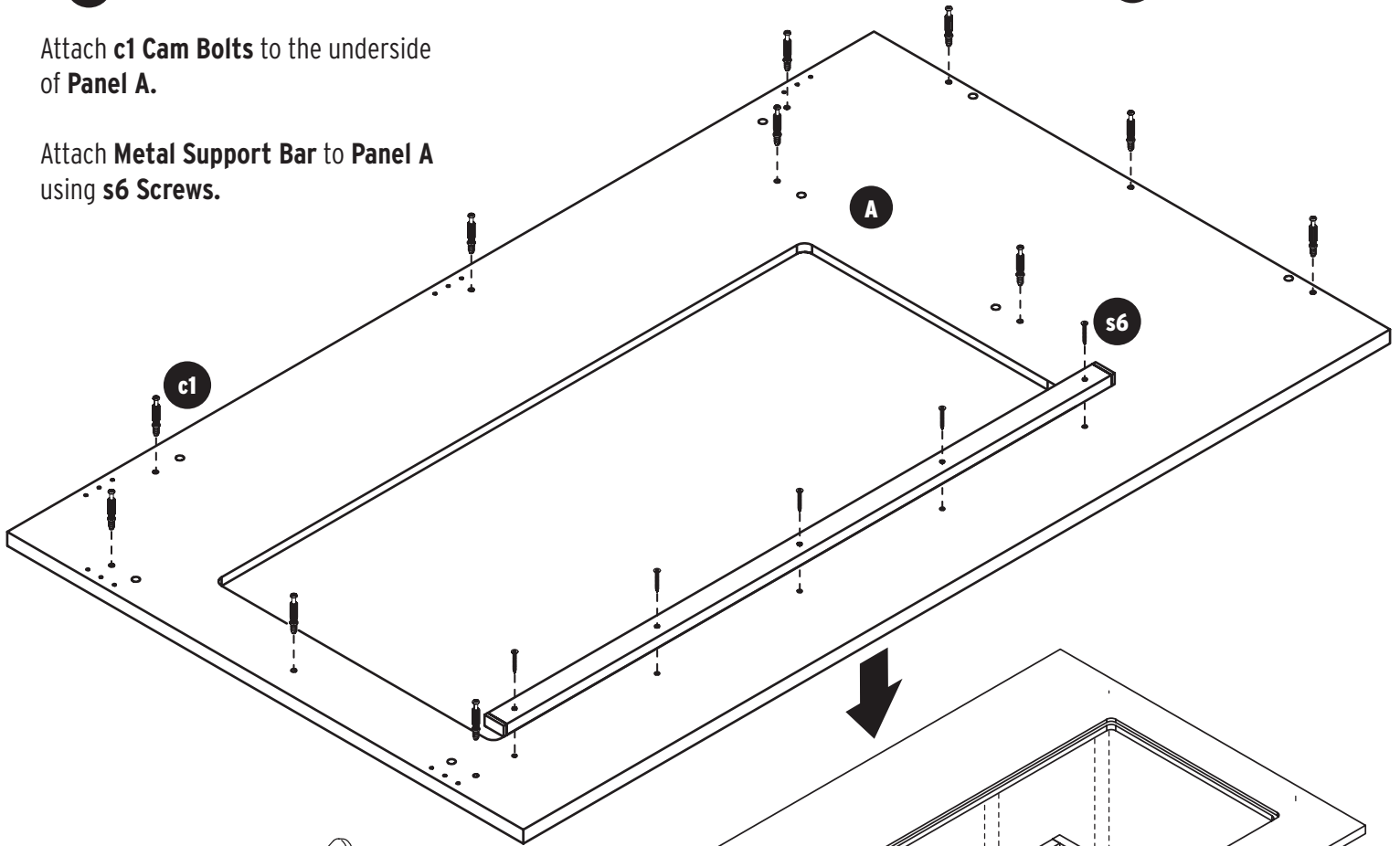

c2 5/8" Cam Cover **x11**

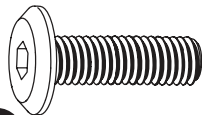

b12 6x16 Fix Bolt **x4**



a Allen Wrench **x1**

Attach **Panel A** as shown, carefully lining up Cam Bolts in **Panel A** with Cam Locks on **Panels Z, D, Y and X**.

You may need a second person to help you.

Tighten **Cam Locks** and cover with **Cam Covers**.

Embroidery Arm Holder units are available. If you are not installing one at this point, **b1 Fix Bolts** can be installed in the pre-drilled Embroidery Arm Holder holes on **Panel X**.

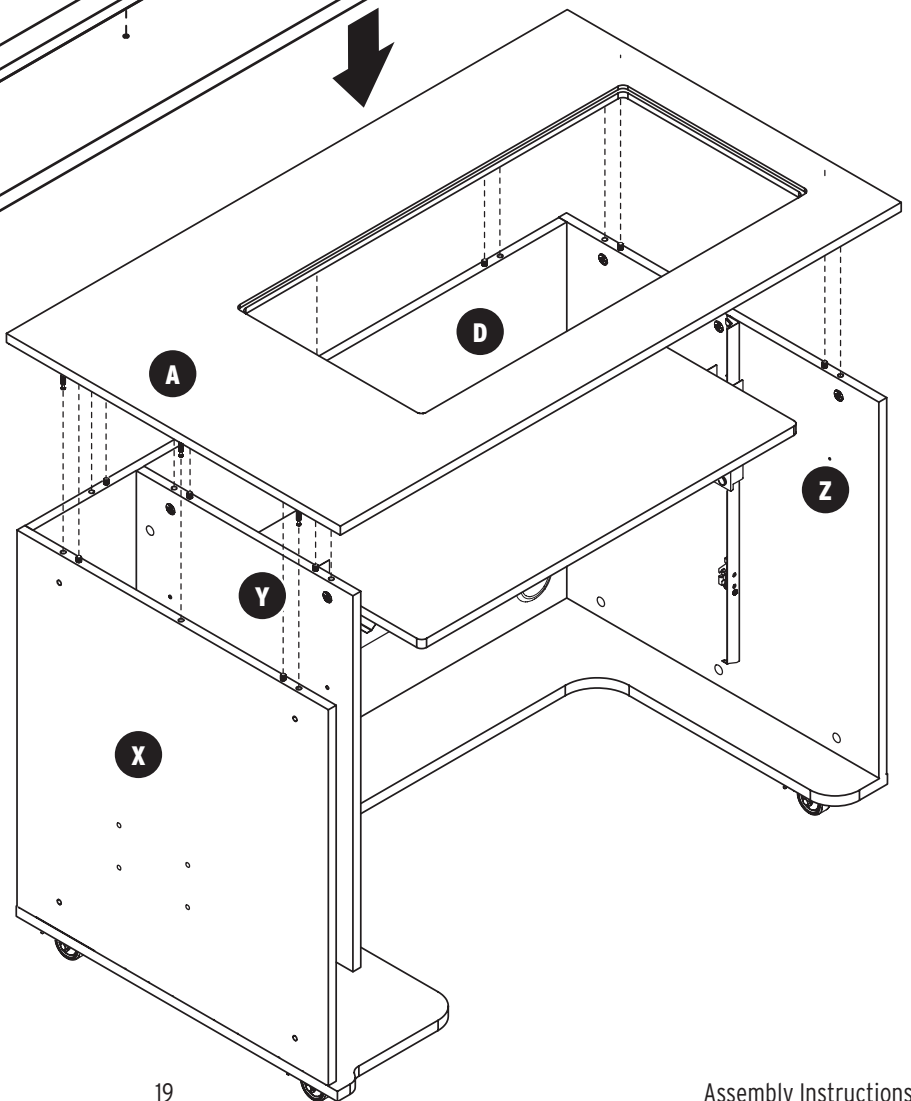

Step 3: Top and Leaves

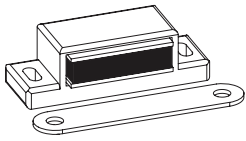

m Magnet **x0**
Catch Plate **x2**

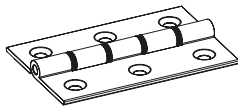

h3 Butt Hinge **x4**

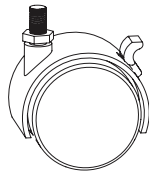

t1 Caster **x2**



s1 3.5x14 Screw **x24**



s2 3x14 Screw **x4**



s5 Alignment Pin **x2**

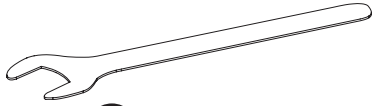

r3 14mm Wrench **x1**

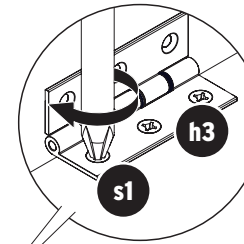

Install **h3** Butt Hinges using **s1** Screws.

Attach **m** Magnet Catch Plates **m** using **s2** Screws.

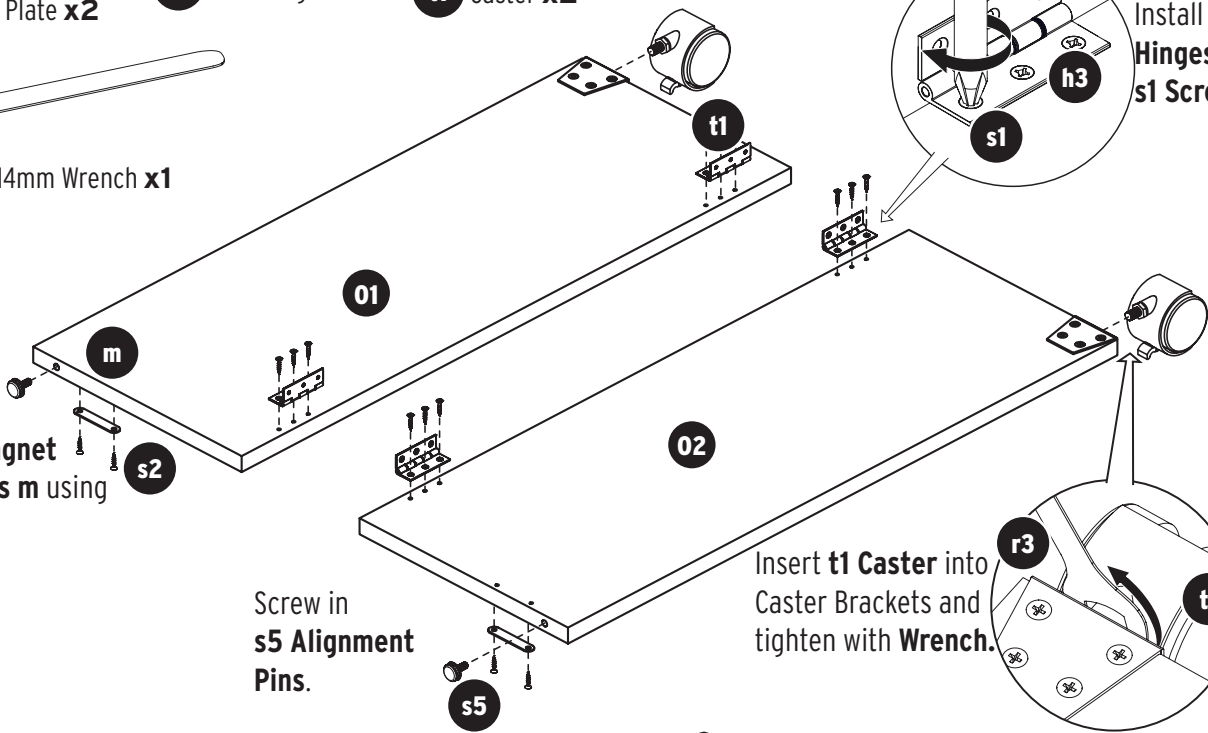

Screw in **s5** Alignment Pins.

Insert **t1** Caster into Caster Brackets and tighten with Wrench.

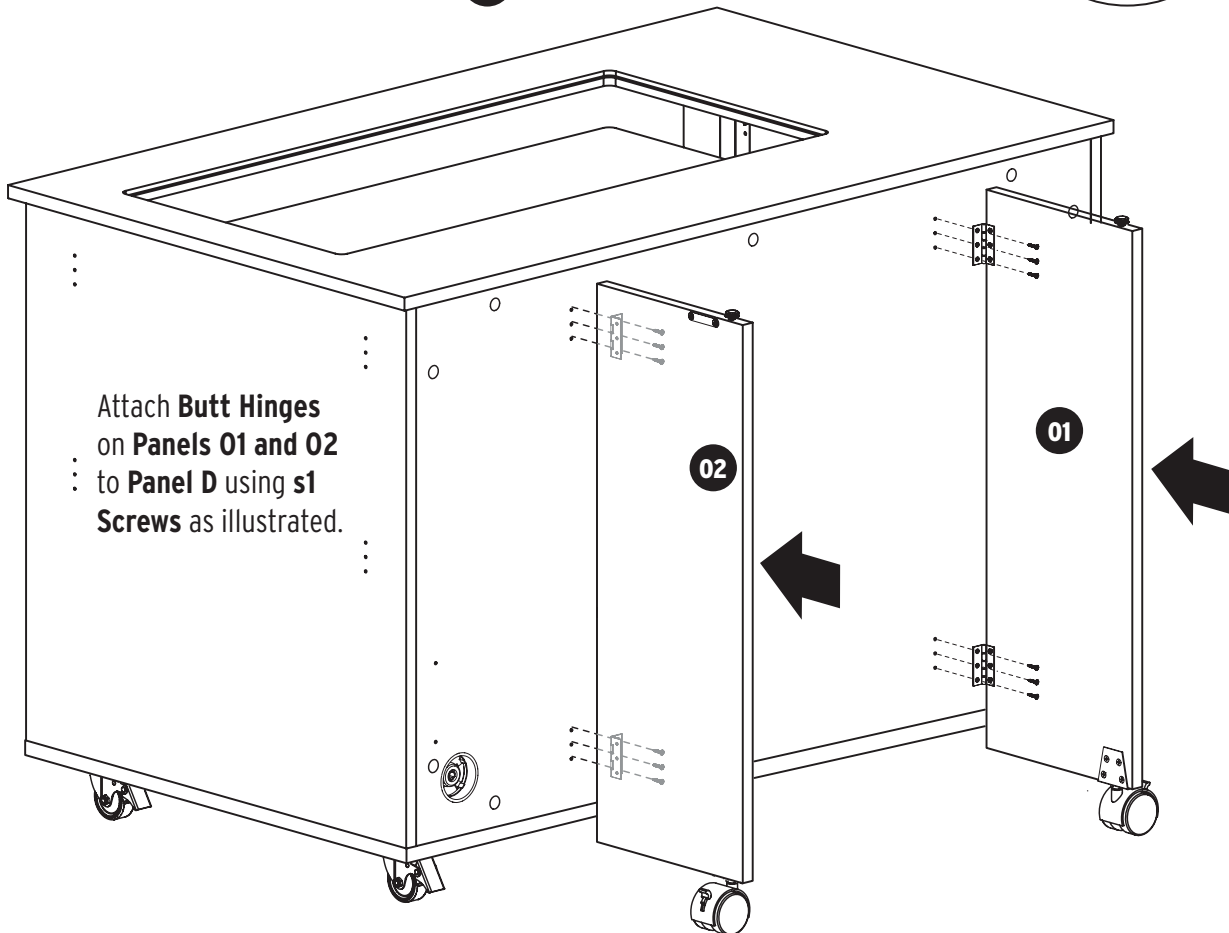
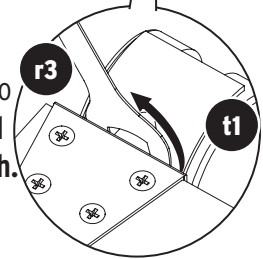

Attach **Butt Hinges** on **Panels 01 and 02** to **Panel D** using **s1** Screws as illustrated.

Step 3: Top and Leaves



s1 3.5x14 Screw **x24**

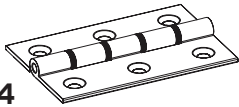

h3 Butt Hinge **x4**

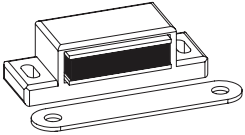

m Magnet **x0**
Catch Plate **x2**

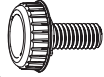

s5 Alignment Pin **x2**



s2 3x14 Screw **x4**

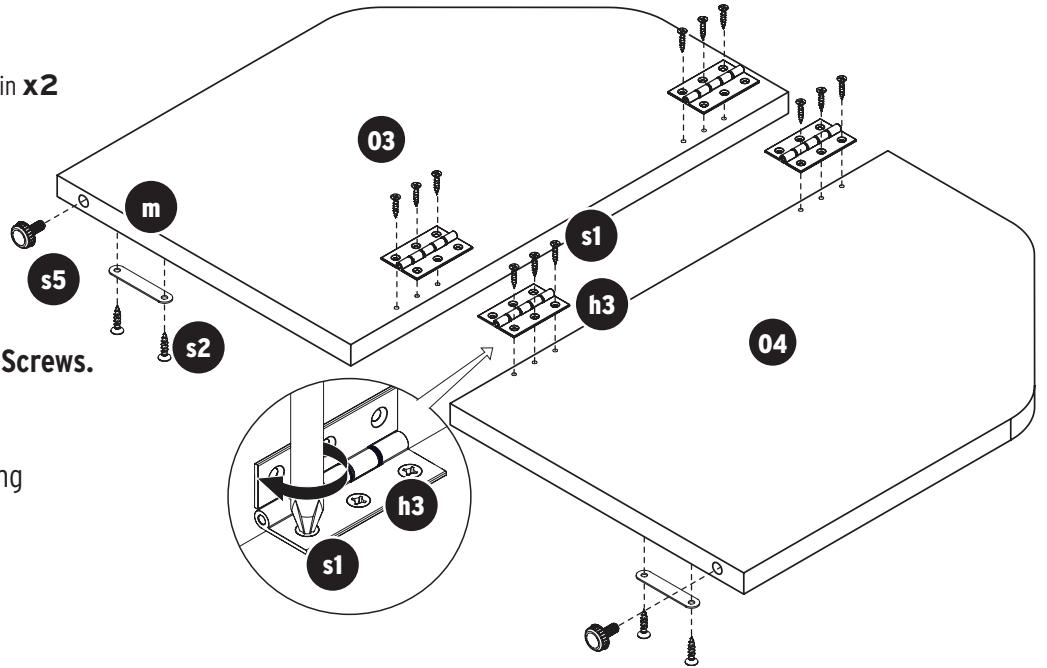

Attach **h3 Butt Hinges** to **Panels 03 and 04**, using **s1 Screws**.

Flip panels over and attach **m Magnet Catch Plates** using **s2 Screws**.

Attach **s5 Alignment Pins**.

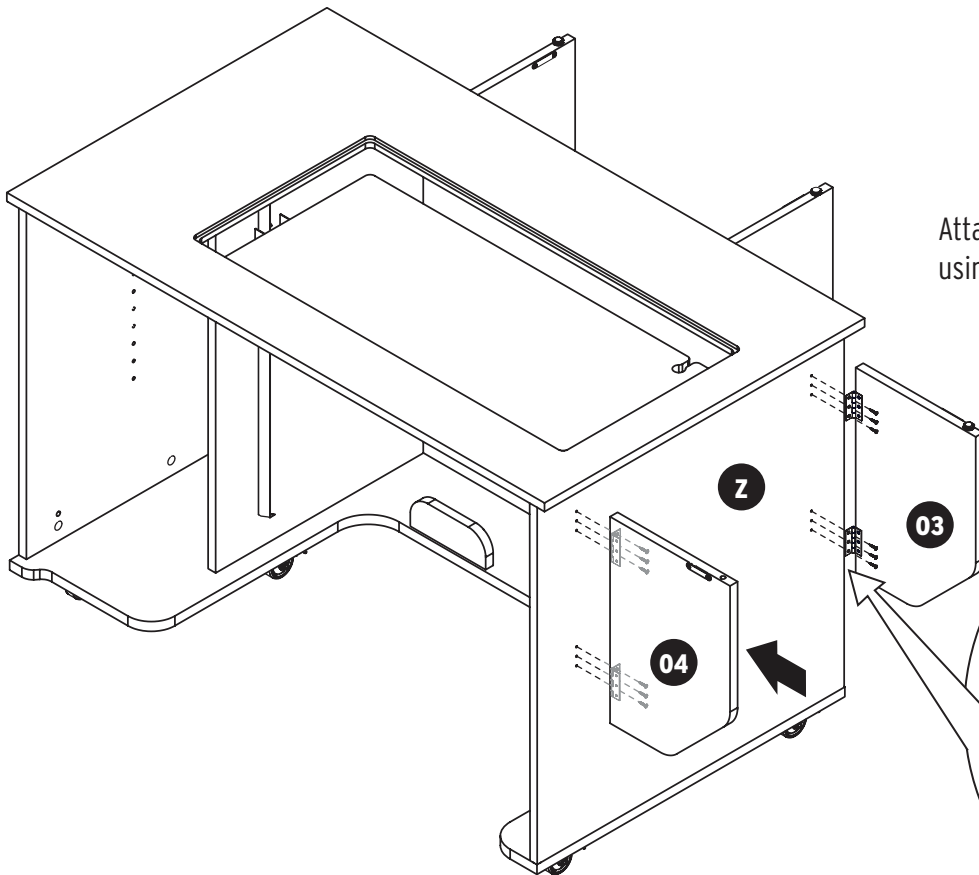

Attach **Panels 03 and 04** to **Panel Z** using **s1 Screws**.

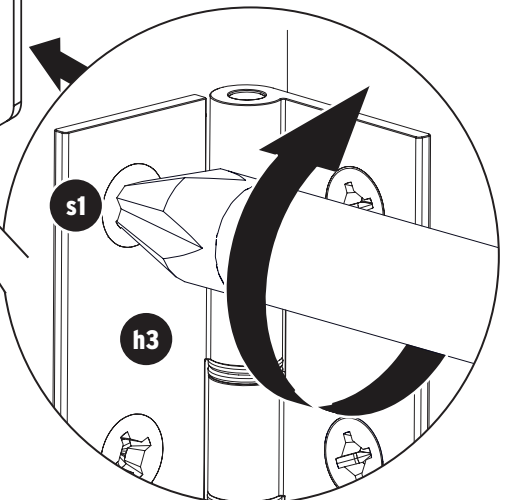

Step 3: Top and Leaves

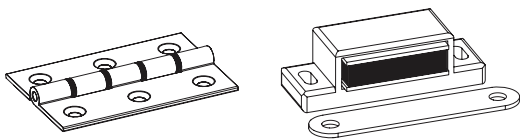

- h3** Butt Hinge **x3**
- m** Magnet **x2**
Catch Plate **x0**
- s1** 3.5x14 Screw **x22**

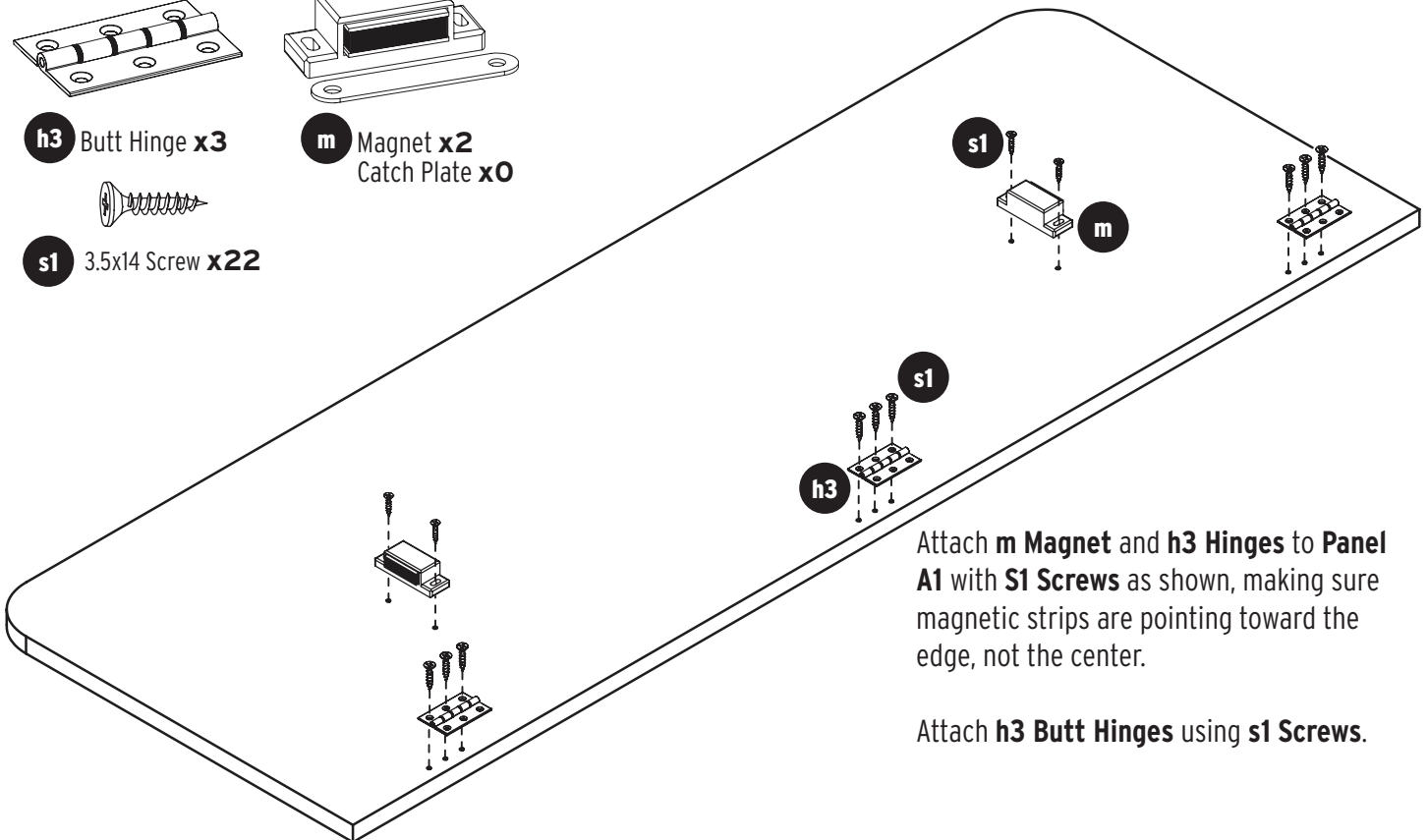

Attach **m Magnet** and **h3 Hinges** to **Panel A1** with **S1 Screws** as shown, making sure magnetic strips are pointing toward the edge, not the center.

Attach **h3 Butt Hinges** using **s1 Screws**.

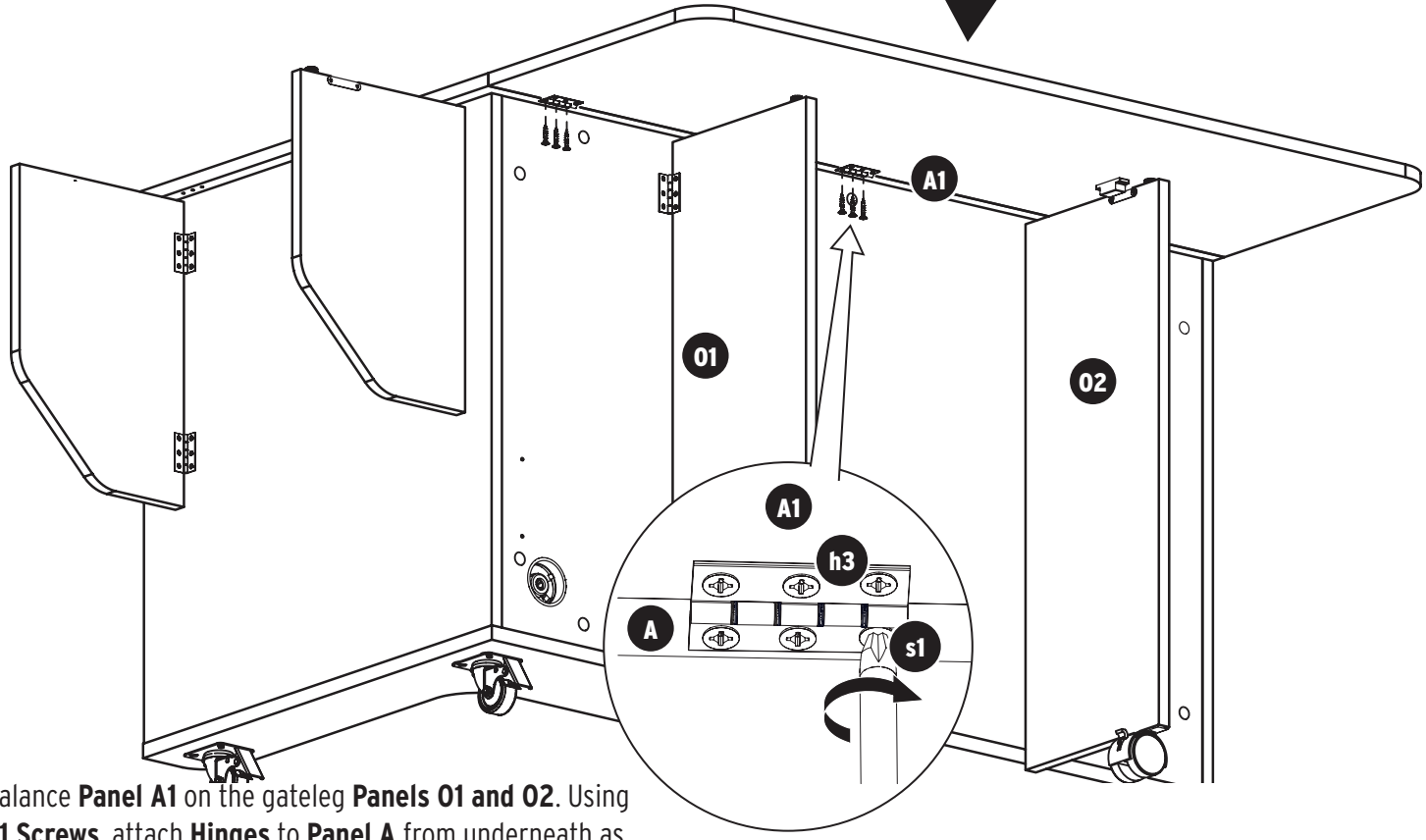

Balance **Panel A1** on the gateleg **Panels 01** and **02**. Using **S1 Screws**, attach **Hinges** to **Panel A** from underneath as shown.

Step 3: Top and Leaves



s1 3.5x14 Screw **x16**

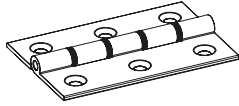

h3 Butt Hinge **x2**

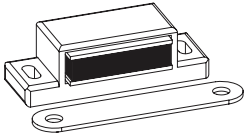

m Magnet **x2**
Catch Plate **x0**

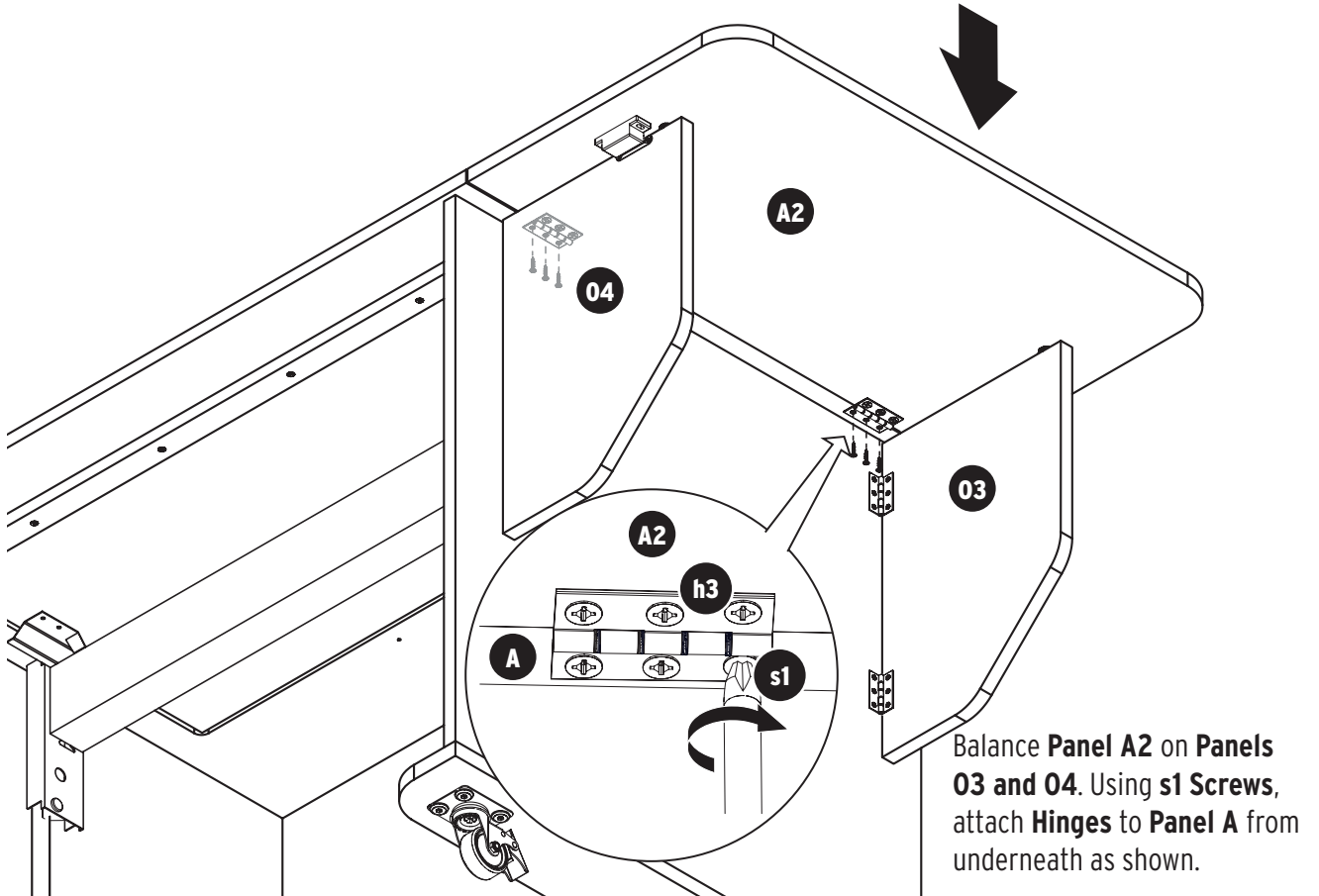
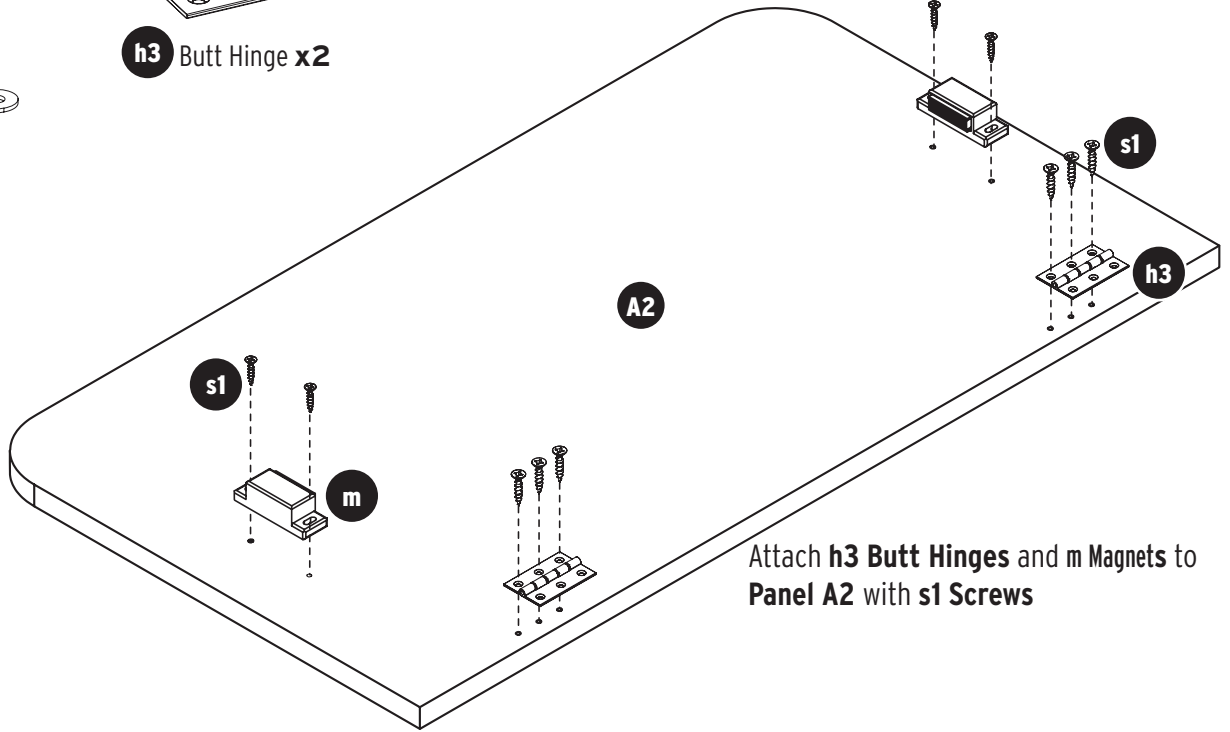

Step 7: Embroidery Arm/Shelf Compartment

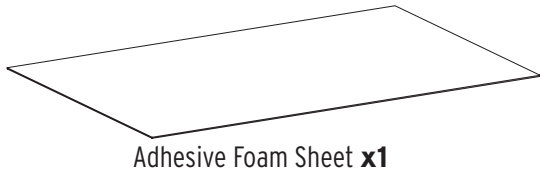

Remove the backing from the **Adhesive Foam Sheet** and carefully adhere it to the bottom of the shelf compartment. **NOTE:** The **Adhesive Foam Sheet**'s adhesive is very strong. Be precise when installing!

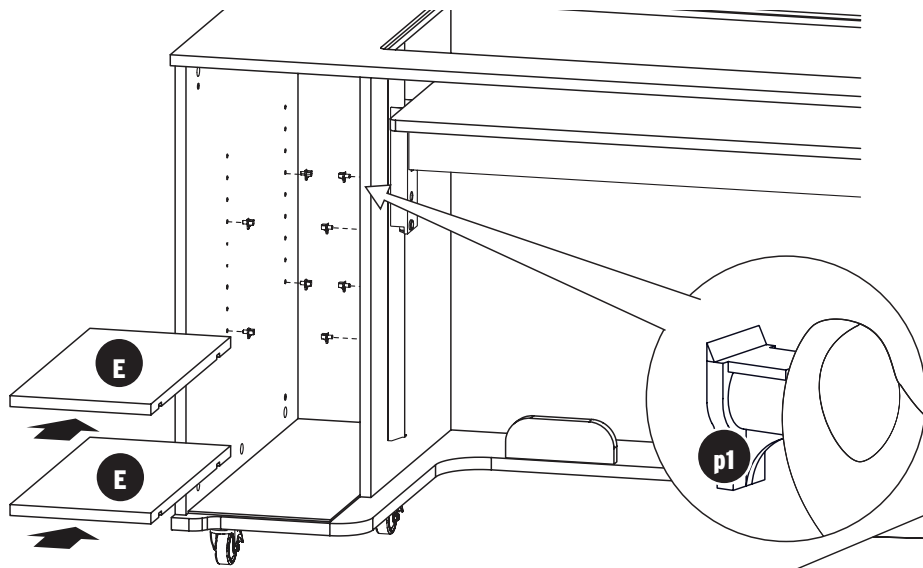
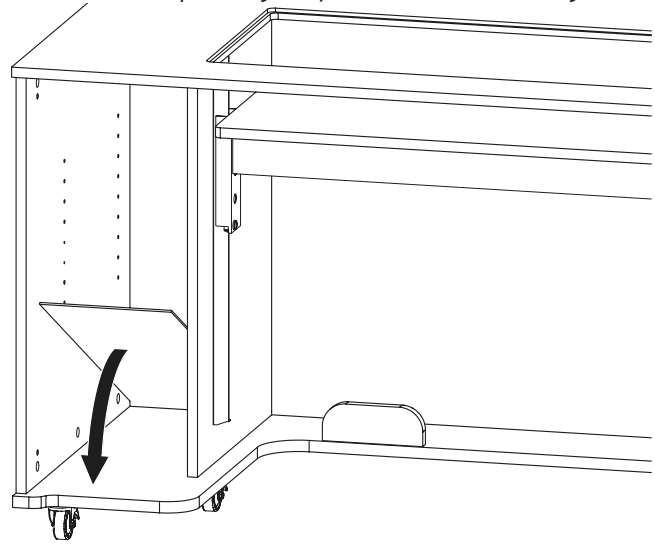
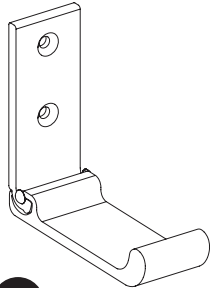

Press **p1 Pegs** into pre-drilled holes as shown, at whatever height you wish.

Slide **Panel E** Shelves on top of **p1 Pegs**.

You may choose to use **h2 Folding Hooks**.

Attach to **Panel Y1** using **s1 Screws**.

Shelves can be used with Folding Hooks.

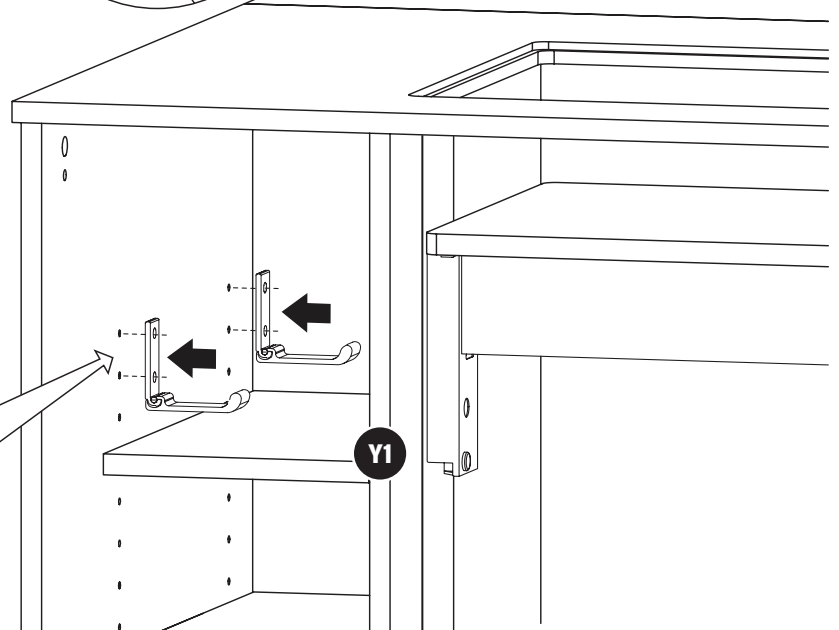
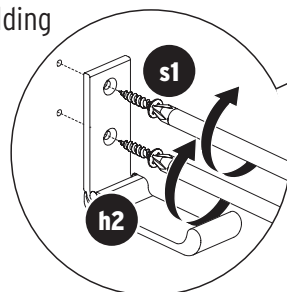

Completed Melbourne Sewing Cabinet

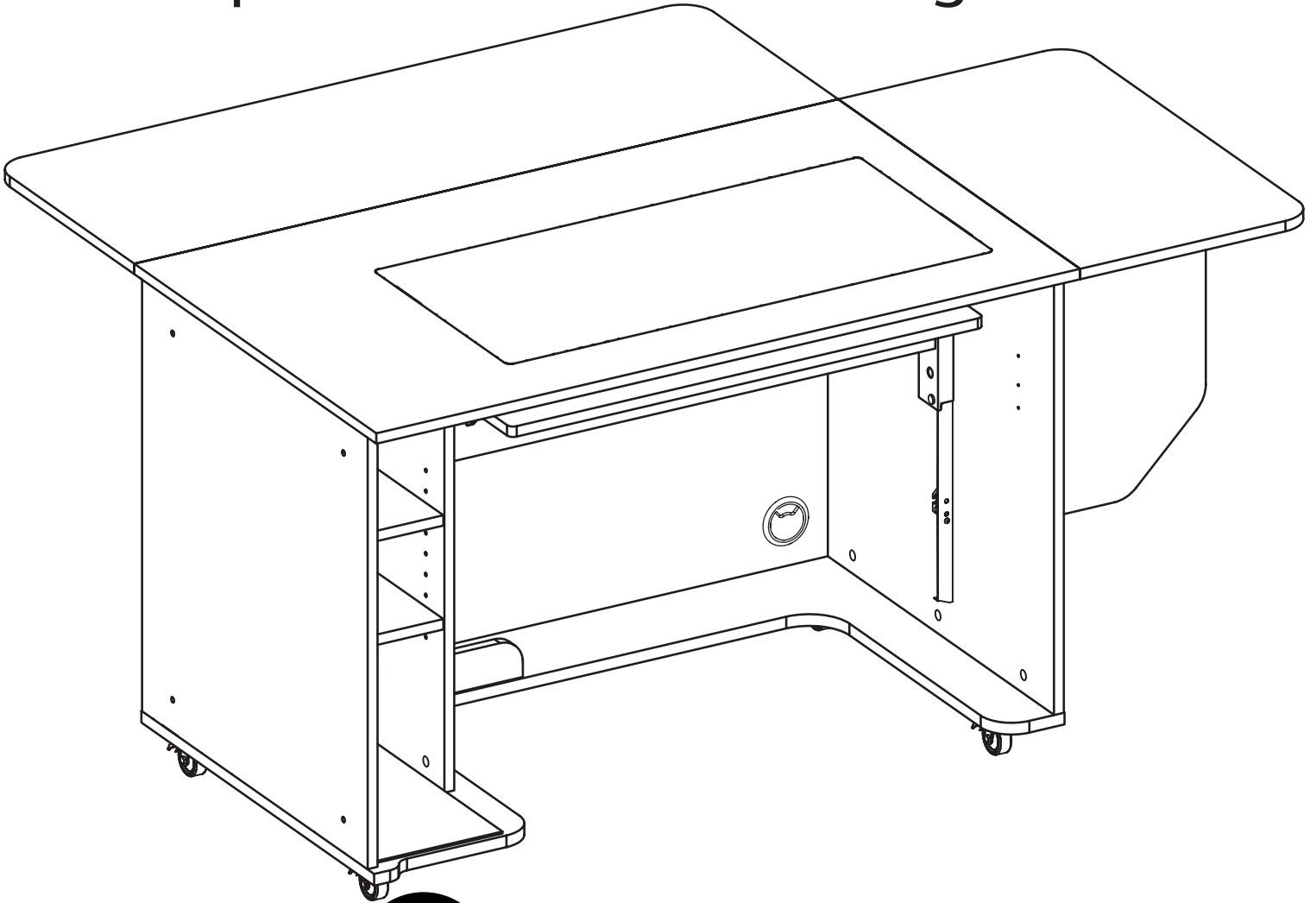

Congratulations! A better sewing experience awaits!

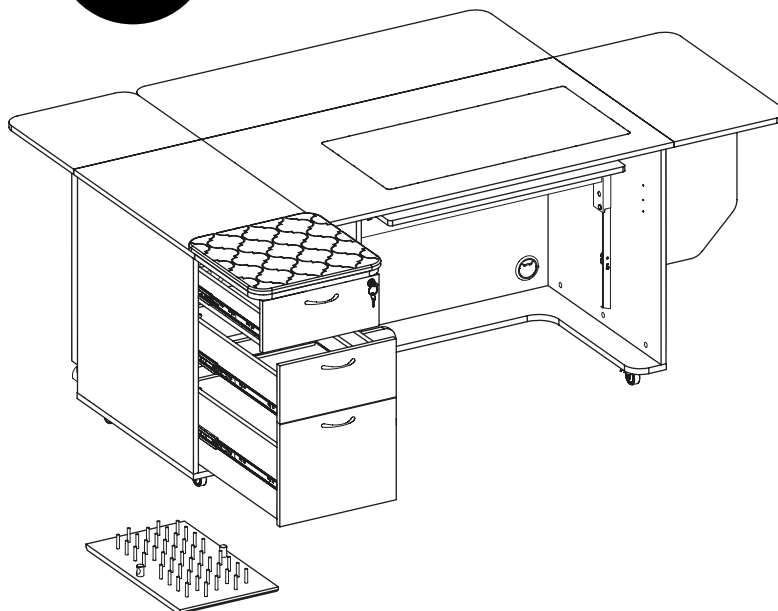

Looking to complete your sewing setup? The Melbourne Sewing Cabinet pairs perfectly with the Adelaide Storage Cabinet to create a fully functional, modular, dynamic sewing and storage solution. Visit www.arrowsewing.com to learn more.

Connecting the Melbourne and Adelaide Parts:

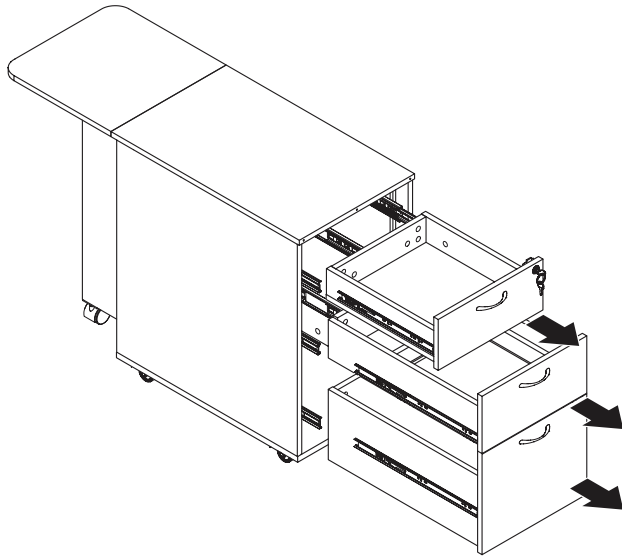
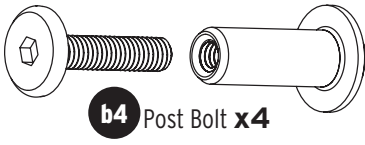

To begin, remove the drawers from the cabinet. To release the drawer from the drawer runner, maneuver the pins on the drawer rails as shown. On the left side of the drawer, the pin moves up. On the right side, the pin moves down.

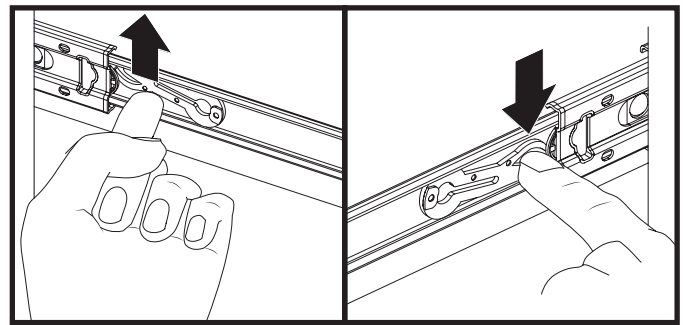

Left side drawer rail

Right side drawer rail

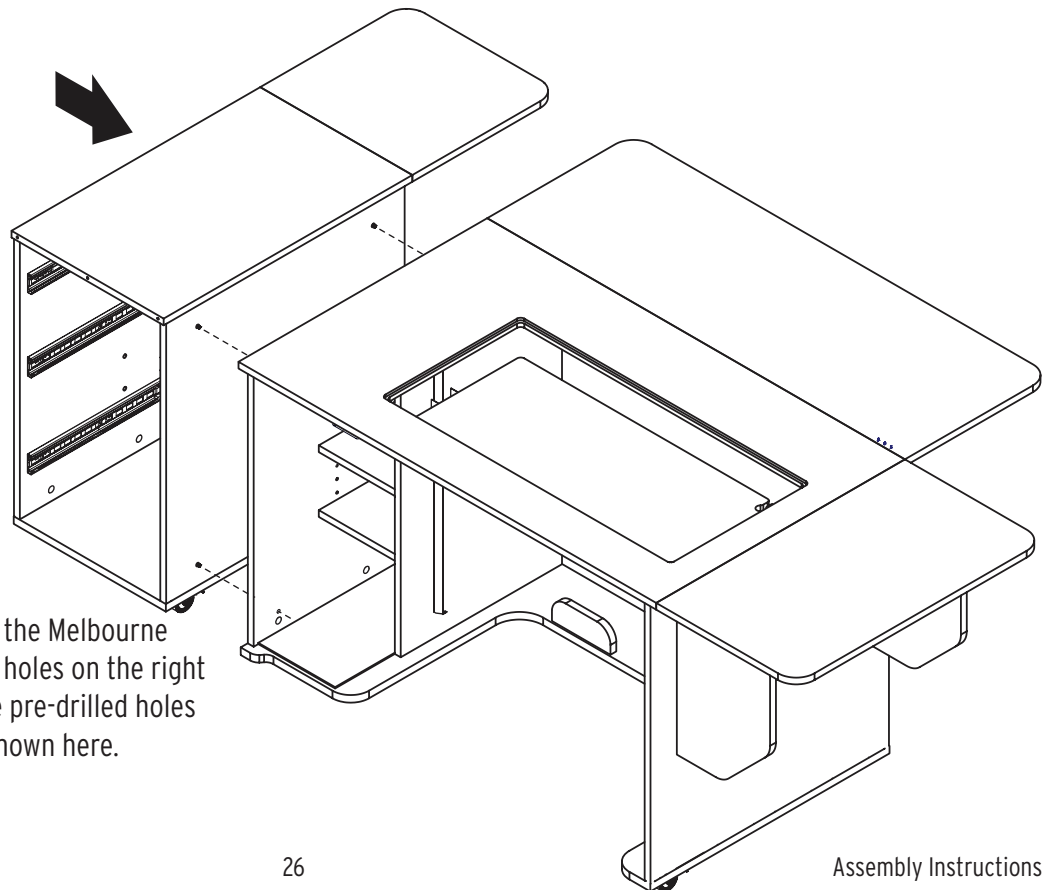

Line the Adelaide storage unit up with the Melbourne sewing cabinet, so that the pre-drilled holes on the right side of the Adelaide match up with the pre-drilled holes on the left side of the Melbourne, as shown here.

Connecting the Melbourne and Adelaide

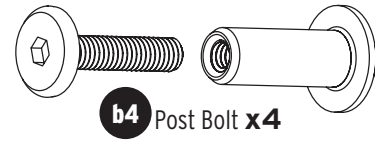
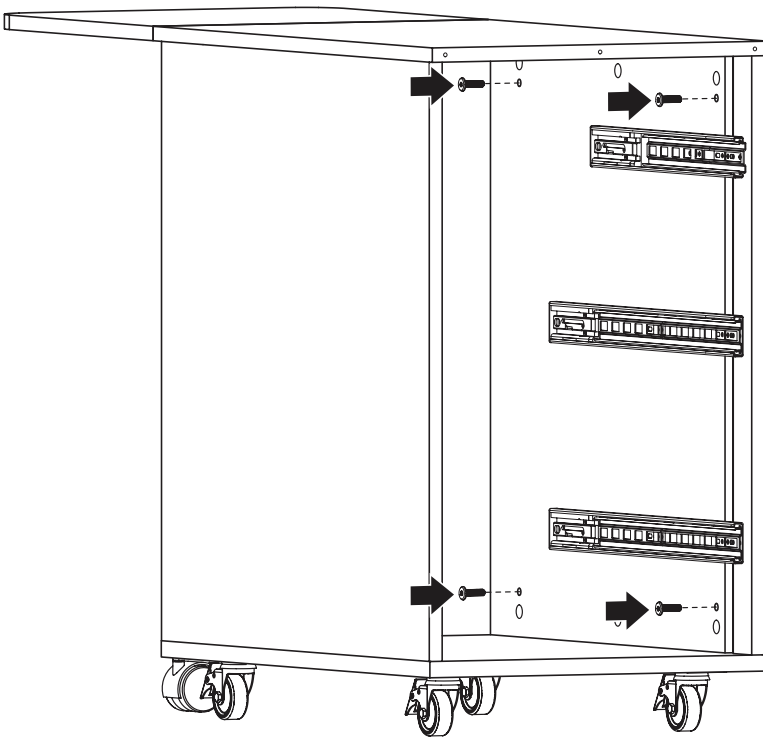

Insert male end of **b4 Post Bolts** through the pre-drilled holes on the Adelaide.

Insert the female end of **b4 Post Bolts** through the pre-drilled holes on the Melbourne.

Tighten with Allen Wrench.

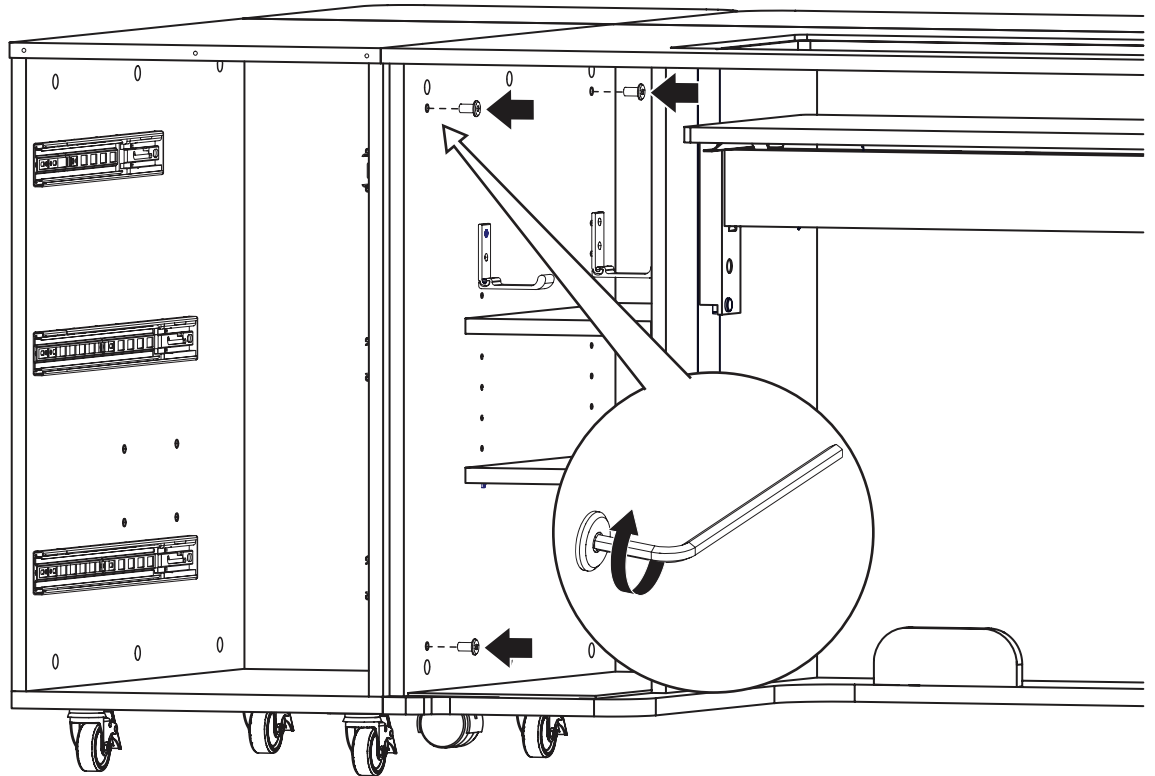



KANGAROO™
sewing furniture

LIMITED LIFETIME WARRANTY

Kangaroo™ Sewing Furniture Limited Lifetime Warranty

WHAT THIS WARRANTY COVERS: Arrow Companies, LLC "Arrow" provides a Limited Lifetime Warranty "Warranty" to the original purchaser of this product against defects in materials or workmanship of furniture components. As used in this Warranty, "defect" means imperfections in components which substantially impair the utility of the product. This Warranty gives you specific legal rights, and you may also have other rights which vary from state to state. Electrical and mechanical components of furniture are warranted for 5 years.

HOW TO GET SERVICE: Simply contact Arrow at 1-800-533-7347 or CS@ArrowSewing.com. When you request Warranty service, you must also present proof of purchase documentation, which includes the date of purchase (detailed receipt), and photos of the product. Arrow will replace any defective part (at its sole option), excluding labor. Replacement parts will be warranted for only the remaining period of the original Warranty.

Replacement parts will be shipped freight prepaid on any initial Warranty claim during first year of Warranty only. Warranty applies only to defects confirmed by Arrow and will be replaced or repaired at Arrow's option. In the event parts are no longer available for a Warranty claim, customer may receive a brand new cabinet at a price equal to 60% off the MSRP of a current comparable model.

WHAT'S NOT COVERED: There is no Warranty coverage for defects or conditions that result from the following: Failure to follow product assembly instructions, information or warnings; misuse or abuse; intentional damage; fire, flood, alteration or modification of the product; use of the product in a manner inconsistent with its intended use; any condition resulting from incorrect or inadequate maintenance, cleaning, care or neglect; cuts or scratches; caster damage as a result of moving furniture fully loaded or with locked casters; damage resulting from electrical surge or lightning; or use in commercial or education environments. Arrow Sewing Furniture is designed for residential use only.

ARROW SHALL HAVE NO LIABILITY for ANY INCIDENTAL OR CONSEQUENTIAL DAMAGES OF ANY KIND and all such damages are EXCLUDED FROM THIS Warranty, such as loss of use, disassembly, transportation, labor, or damage to property on or near the product. Some states do not allow the exclusion or limitation of incidental or consequential damages, so the above limitation or exclusion may not apply to you. The Warranty cannot be transferred to subsequent owners or users of the product, and it shall be immediately void in the event the product is resold, transferred, leased or rented to any third party or person other than the original purchaser.

ADDITIONAL LIMITATIONS: THERE ARE NO OTHER WARRANTIES APPLICABLE TO THIS PRODUCT. Under the laws of certain states, there may be no implied warranties from Arrow and all implied warranties, INCLUDING ANY IMPLIED Warranty OF MERCHANTABILITY OR FITNESS FOR A PARTICULAR PURPOSE are disclaimed where allowed by law. TO THE EXTENT ANY IMPLIED WARRANTIES ARE APPLICABLE, ANY IMPLIED WARRANTIES, INCLUDING ANY IMPLIED Warranty OF MERCHANTABILITY OR FITNESS FOR A PARTICULAR PURPOSE, ARE LIMITED IN DURATION TO THE DURATION OF THIS EXPRESS Warranty or the minimum period allowed by law, whichever is shorter. Some states do not allow limitations on how long an implied Warranty lasts, so the above limitation may not apply to you. This limited Warranty gives you specific legal rights. This limited Warranty does not, in any way, affect the rights given to you by law.

REGISTER YOUR PRODUCT: Original purchaser should register the purchase online at www.ArrowSewing.com/Warranty.

SEW IN COMFORT. SEW LONGER.™

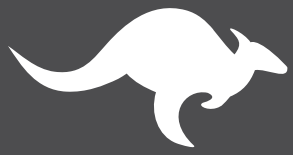

Accessories to Complete Your Sewing Studio

Custom Insert

Enhance your sewing experience with a custom acrylic sewing insert! Custom acrylic sewing inserts are designed to fill the gap between your sewing machine and sewing cabinet's lift opening to create a flush, ergonomic surface for flat bed sewing. To ensure a perfect fit, custom acrylic sewing inserts are built specifically for your sewing machine and sewing cabinet combination. Say hello to happy wrists, straighter stitches, and an elevated sewing experience!

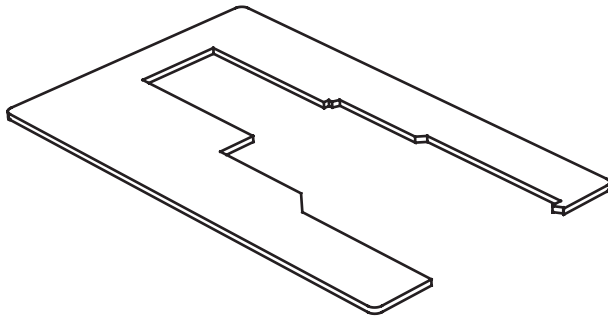

Insert

Arrow Sewing Chairs

Arrow's #1 Rated Height Adjustable Sewing Chair is a must have accessory for your dream sewing room! Cute, comfortable and convenient - our lovable sewing chairs feature vibrant sewing themed patterns, 360 swivel access and lumbar support for long hours at your workstation. Don't look now, but under every seat cushion is a hidden storage compartment to store your notions and patterns! Available in 10 colors to perfectly match your sewing sanctuary!

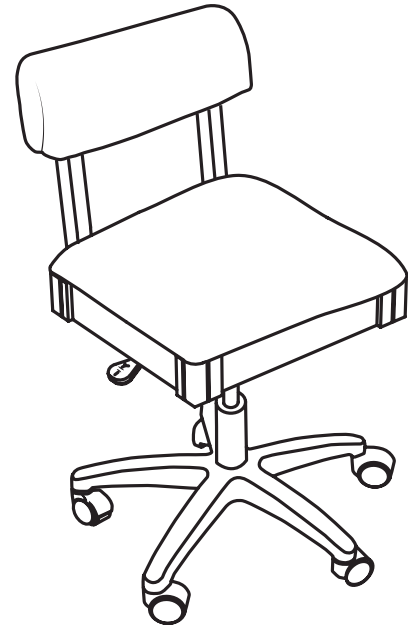

Height Adjustable Sewing Chair

P.O. Box 410 Elkhorn, WI 53121
1-800-533-7347 Ext. 1
CS@ArrowSewing.com
www.ArrowSewing.com

11-25